



P 120

Part 4 (44)

AUTOMATIC
TRANSMISSION
(BW - 35)

CARS

**SERVICE
MANUAL**

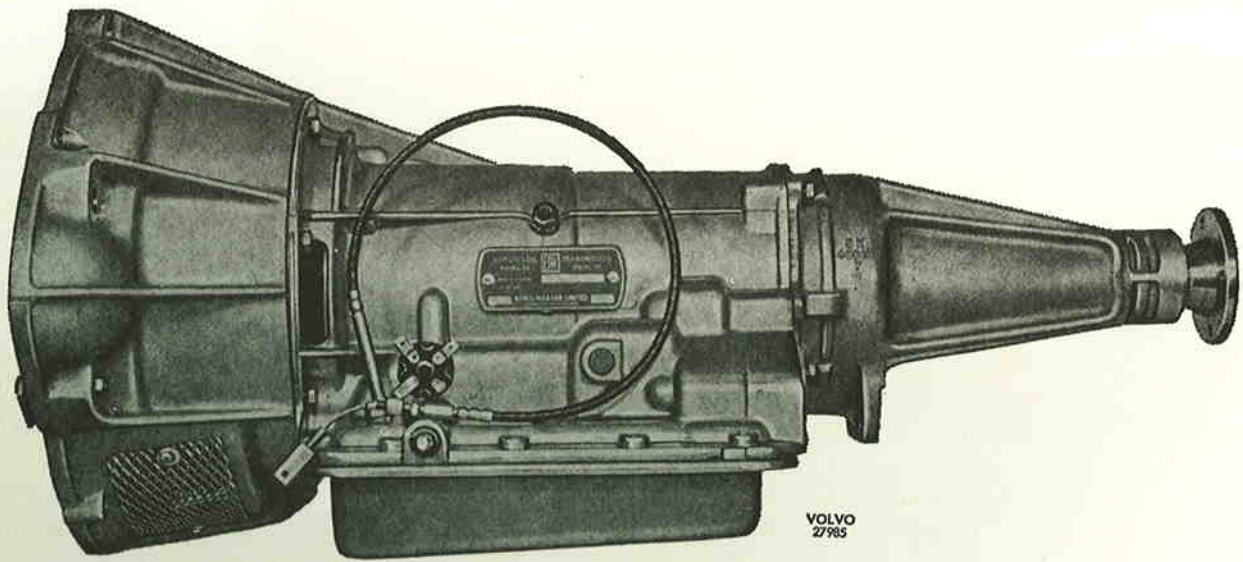

Fig. 1. The Borg-Warner Automatic Transmission type 35.

List of contents

Description	4-1
Maintenance and repair instructions	4-15
Checking fluid level	4-15
Adjusting selector controls	4-15
Adjusting downshift valve cable	4-15
Adjusting starter inhibitor switch	4-17
Adjusting front brake band	4-17
Adjusting rear brake band	4-17
Air pressure checks	4-18
Removing	4-19
Dismantling	4-19
Inspecting	4-24
Assembling	4-24
Selector controls	4-30
Fault-tracing	4-31
Special tools	4-34
Specifications	4-35
Fault-tracing chart	4-37

In all correspondence with AB Volvo concerning the guarantee, servicing and spare parts the serial number of the transmission must always be stated. This also applies to the converter, which does not have a manufacturing serial number.

Note that all questions concerning the guarantee servicing, spare parts, etc., are dealt with by AB Volvo. No correspondence should be sent to the manufacturer.

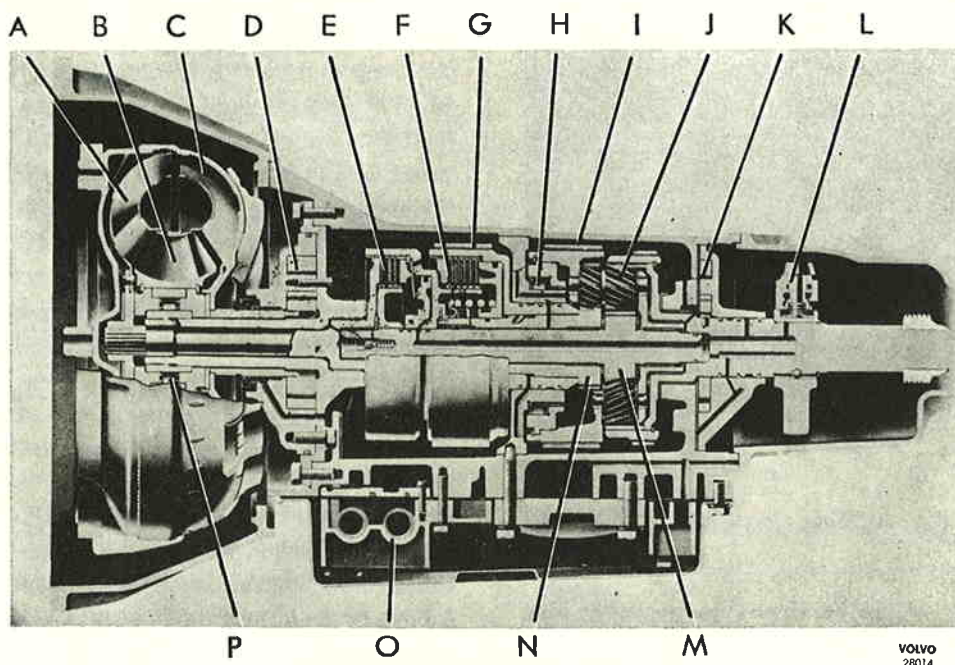

Fig. 2. Sectioned view of the transmission.

- | | | |
|-----------------------|------------------------------|--------------------------------|
| A. Turbine | G. Front brake band | M. Forward sun gear |
| B. Stator | H. One-way clutch in gearbox | N. Reverse sun gear |
| C. Impeller and cover | I. Rear brake band | O. Control system |
| D. Front pump | J. Planetary gear set | P. One-way clutch in converter |
| E. Front clutch | K. Rear pump | |
| F. Rear clutch | L. Governor | |

DESCRIPTION

The Volvo automatic transmission for cars is of Borg-Warner manufacture, type 35. It consists of two main components:

1. A three-element hydrokinetic torque converter coupling capable of torque multiplication at an infinitely variable rate between 2:1 and 1:1.
2. A hydraulically operated gearbox comprising a planetary gear set with a valve system which automatically selects a suitable gear in relation to the speed of the car and position of the accelerator pedal.

There is also a selector control with positions "L", "D", "N", "R" and "P", see Fig. 3.

THE TORQUE CONVERTER

The torque converter serves both as a clutch and as an extra (hydraulic) gear between the engine and gearbox. It provides a means of obtaining smooth application of engine power to the driving wheels and additional engine torque multiplication to the 1st

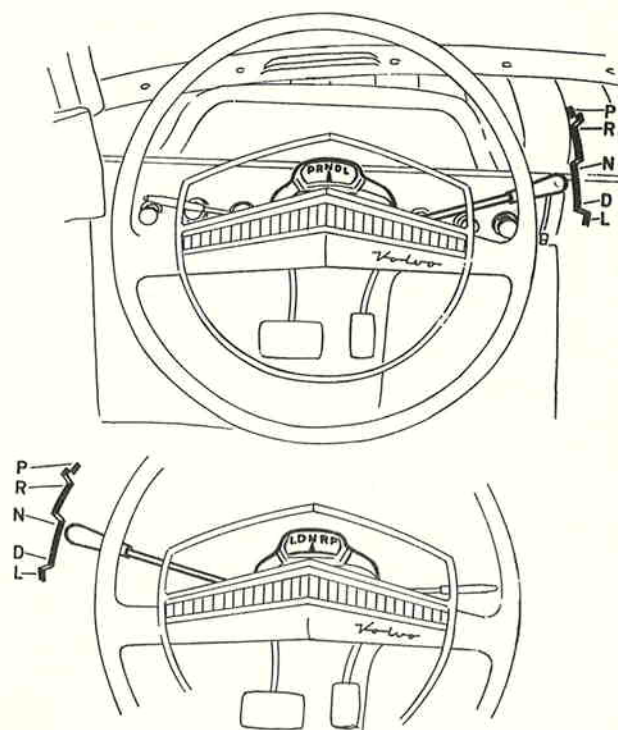
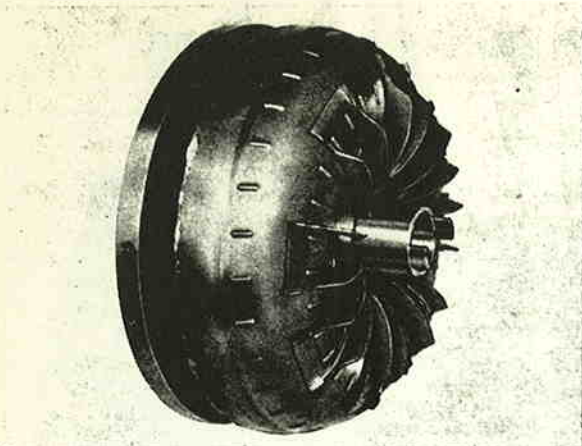

Fig. 3. Selector lever positions.

VOLVO
27986



VOLVO
27667

Fig. 4. The converter.

and 2nd gears of the gearbox. The converter also provides extreme low-speed flexibility when the gearbox is in 3rd gear and, due to the ability of multiplying engine torque, it provides good acceleration from very low road speed without having to resort to a downshift in the gearbox.

The converter consists of three main components — an impeller connected to the engine crankshaft, a turbine connected to the input shaft of the gearbox, and a stator mounted on a sprag-type one-way clutch supported on a fixed hub projecting from the gearbox case.

The converter functions as follows:

The impeller is rotated by the engine and converts the engine power into hydrokinetic energy. The fluid flows from the impeller vanes to the turbine vanes and returns to the impeller through the stator vanes,

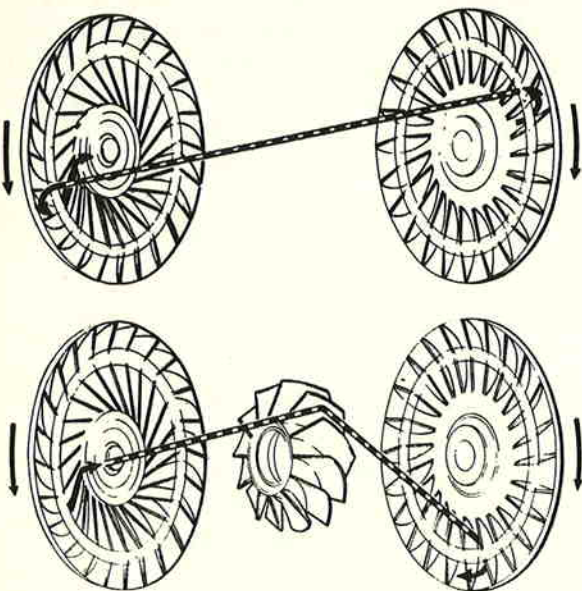

VOLVO
27978

Fig. 5. Function of converter.

see Fig. 5. The curvature of the various vanes is so designed that when a speed differential exists between the impeller and the turbine, the angle of the fluid flow from the turbine is changed by the stator vanes in such a way that the discharge of fluid from the stator assists in driving the impeller. Under such conditions, torque multiplication occurs and varies from 2:1 when the turbine is stalled (i.e. when, with any of the driving ranges selected, the vehicle is held stationary and the engine is operating at maximum throttle opening) to 1:1 when the turbine reaches a speed approximately 90 % of that of the impeller. When this speed differential between the impeller and turbine is achieved, the fluid flow angle from the turbine is such that the stator is driven in the same direction as the turbine and the impeller. Under these circumstances, the converter becomes a fluid flywheel or coupling and there is no torque multiplication.

GEARBOX

The gearbox consists of a mechanical power transmission system — planetary gear, two clutches, two brake bands and a one-way clutch — and a hydraulic system — front and rear pump, centrifugal governor and a control valve system which regulates the fluid pressure and directs the fluid to the various gearbox components.

Mechanical power transmission system

PLANETARY GEAR

The planetary gear set consists of two sun gears, two sets of pinions, a pinion carrier and a ring gear, see Fig. 6. Helical involute tooth forms are used throughout. In all forward gears, power enters through the forward sun gear; in reverse, power enters through the reverse sun gear. Power leaves the gear set by the ring gear. The pinions are used to transmit power

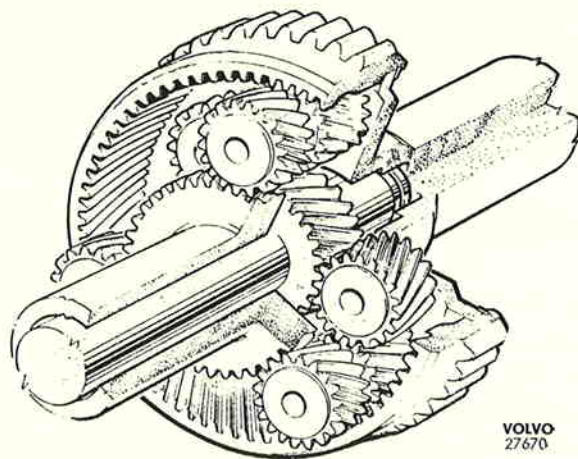

VOLVO
27670

Fig. 6. Planetary gear.

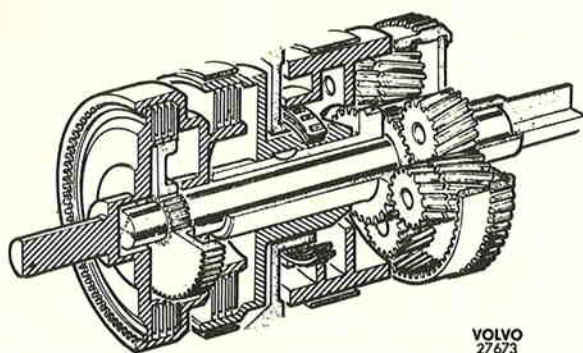

Fig. 7. Planetary gear, clutches and brake bands.

from the sun gears to the ring gear. In reverse, a single set of pinions is used which causes the ring gear to rotate in the opposite direction to the sun gear. In forward gears, a double set of pinions is used to cause the ring gear to rotate in the same direction as the sun gear. The carrier locates the pinions in their correct positions relative to the two sun gears and the ring gear (and also forms a reaction member in certain conditions). The various mechanical ratios of the gear set are obtained by the engagement of hydraulically operated multi-disc clutches and brake bands.

CLUTCHES

The clutches, see Fig. 7, consist of multi-disc units operated by hydraulic pistons. In all forward gears the front clutch connects the converter to the forward sun gear; for reverse, the rear clutch connects the converter to the reverse sun gear.

BRAKE BANDS

Brake bands, operated by hydraulic servos, hold elements of the gear set stationary to effect an output speed reduction and a torque increase. In "lock-up", the rear band holds the pinion carrier stationary and provides the 1st gear ratio of 2.39:1 and, in reverse, a ratio of 2.09:1. The front band holds the reverse sun gear stationary to provide the 2nd gear ratio of 1.45:1.

ONE-WAY CLUTCH

In the drive position "D", a one-way clutch is used in place of the rear band to prevent the pinion carrier from turning opposite to engine rotation, thus also providing a 1st gear ratio of 2.39:1. This one-way clutch, allowing the gearbox to freewheel in 1st gear, provides smooth ratio changes from 1st to 2nd and vice versa.

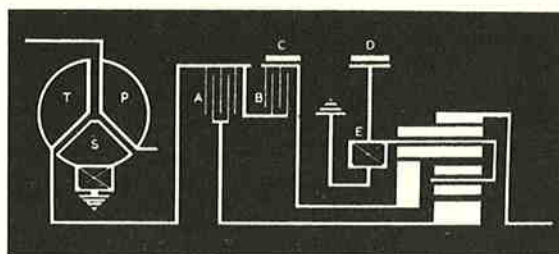

VOLVO 27979

	A	B	C	D	E
1st gear, L	●			●	
1st gear, D	●				●
2nd gear	●		●		
3rd gear	●	●			
Neutral					
Reverse		●		●	
Park					

Fig. 8. Diagram of power flow.

- A. Front clutch
- B. Rear clutch
- C. Front brake band
- D. Rear brake band
- E. One-way clutch
- P. Impeller
- S. Stator
- T. Turbine

POWER FLOW

1st gear ("lock-up" selected)

The front clutch is applied, connecting the converter to the forward sun gear, see Fig. 9. The rear brake band is applied, holding the pinion carrier stationary; the gear set provides the reduction of 2.39:1. The reverse sun gear rotates freely in the opposite direction to the forward sun gear.

1st gear, (drive selected)

The front clutch is applied, connecting the converter to the forward sun gear, see Fig. 10. The one-way clutch is in operation preventing the pinion carrier from turning opposite to engine rotation; the gear set provides the reduction of 2.39:1. On the overrun, the one-way clutch, and thus the gearbox, freewheels.

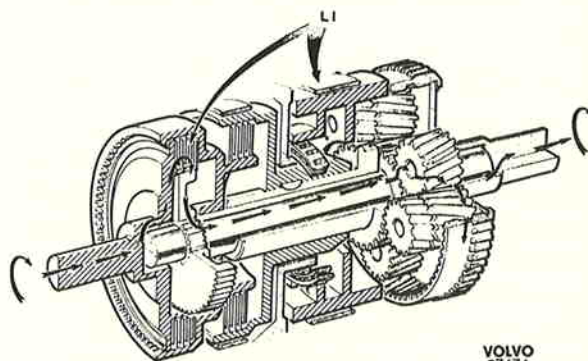

VOLVO 27674

Fig. 9. Power flow, 1st gear, position "L".

2nd gear ("Lock-up" or "drive" selected)

Again the front clutch is applied, connecting the converter to the forward sun gear, see Fig. 11. The front brake band is applied holding the reverse gear stationary; the gear set provides a reduction of 1.45: 1.

3rd gear

Again the front clutch is applied, connecting the converter to the forward sun gear, see Fig. 12. The rear clutch is applied, connecting the converter also to the reverse sun gear; thus both sun gears are locked together and the gear set rotates as a unit providing a ratio of 1: 1.

Neutral and park

The front and rear clutches are off and no power is transmitted from the converter to the gear set. The front and rear brake bands are also released, except in "park", where for constructional reasons the rear brake band is applied as long as the engine is running.

Reverse

The rear clutch is applied, connecting the converter to the reverse sun gear, see Fig. 13. The rear brake band is applied, holding the pinion carrier stationary; the gear set provides the reduction of 2.09: 1 in the reverse direction.

Hydraulic system

FRONT PUMP

The front pump, which is driven by two fingers on the converter impeller hub, is in operation whenever the engine is running. This pump supplies the hydraulic requirements of the transmission with the engine running when the vehicle is stationary, as well as at low vehicle speeds before the rear pump becomes effective. When the rear pump is effective, the front pump check valve closes but a by-pass permits the pump still to supply the converter and lubrication requirements. The front pump then operates at reduced pressure in order to minimize pumping losses.

REAR PUMP

The rear pump is rotated by the driven shaft of the transmission. It is fully effective at speeds above 20 m.p.h. (30 km.p.h.) and then supplies the hydraulic requirements of the transmission. If the engine cannot be started with the car battery, i.e. the front pump is inoperative, the rear pump can, above 20 m.p.h. (30 km.p.h.) provide all hydraulic requirements thus enabling the engine to be started through the transmission by towing.

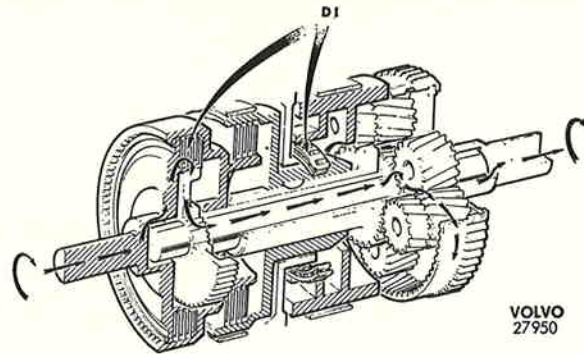

Fig. 10. Power flow, 1st gear, position "D".

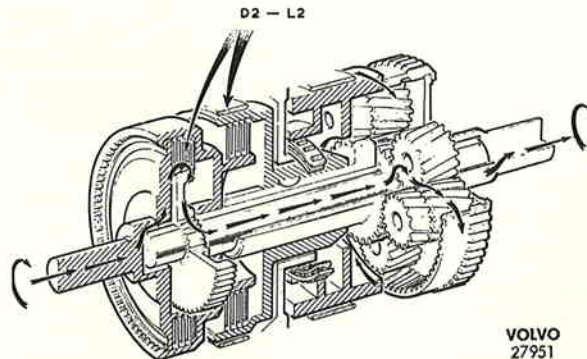

Fig. 11. Power flow, 2nd gear.

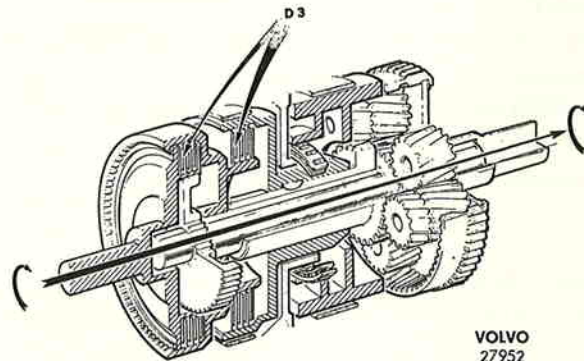

Fig. 12. Power flow, 3rd gear.

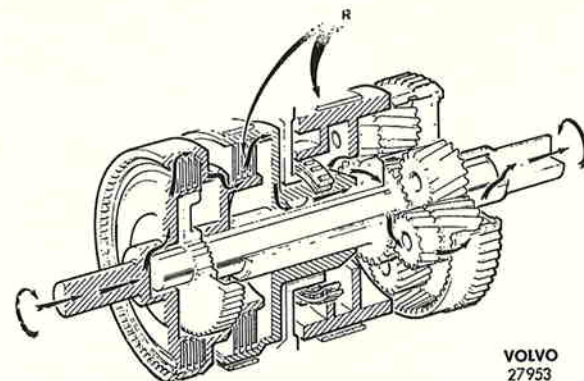

Fig. 13. Power flow, reverse.

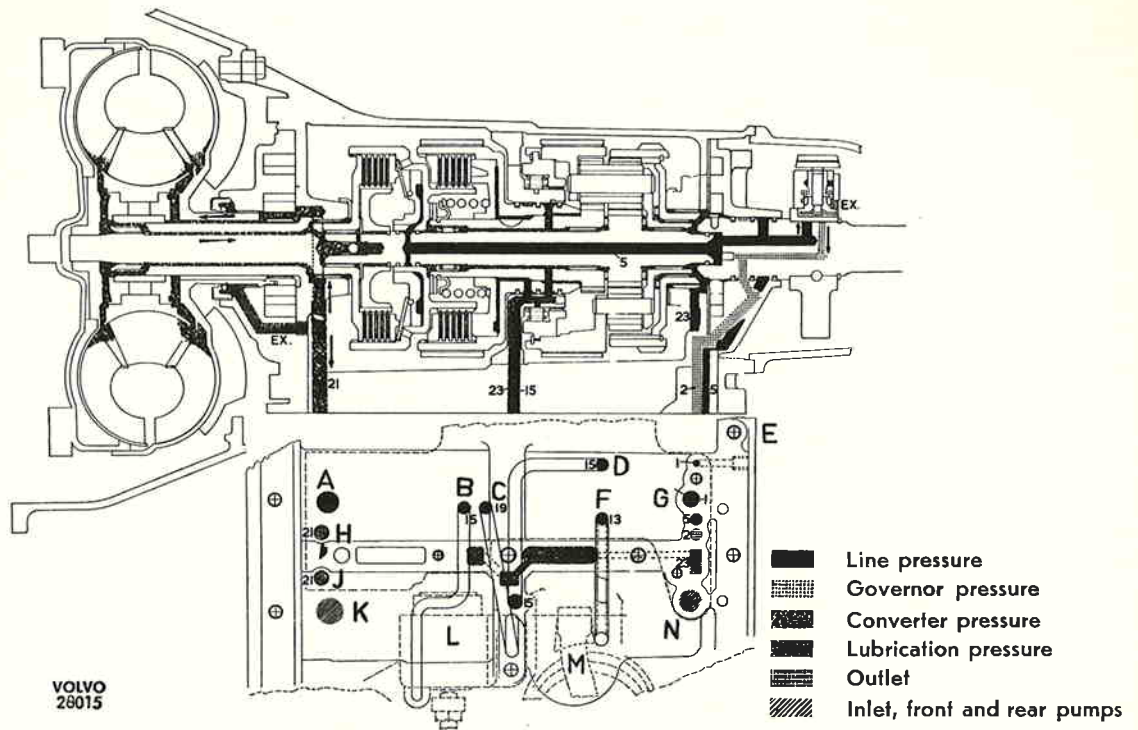

Fig. 14. Fluid passages, transmission and gearbox case.

- | | |
|------------------------------|--------------------------|
| A. Front pump pressure line | H. Converter feed |
| B. Front servo release | J. Converter return line |
| C. Front servo application | K. Front pump inlet |
| D. Rear clutch | L. Front servo |
| E. Outlet for pressure gauge | M. Rear servo |
| F. Rear servo | N. Rear pump inlet |
| G. Rear pump pressure line | |

GOVERNOR

The governor, revolving with the driven shaft, is basically a pressure regulating valve which reduces line pressure to a value that varies with output shaft (i.e. vehicle) speed. This variable pressure, known as governor pressure, is utilized in the control system to effect up and downshifts through the 1—2 and 2—3 shift valves. The rotation of the governor causes the governor weight (C) and valve (B) to produce a centrifugal force, tending to open the valve. This outward force is opposed by an equal and opposite hydraulic force produced by governor pressure acting upon a small area of the governor valve. Due to this, the governor pressure will rise in proportion to the increased centrifugal force caused by increased rotational speed.

As speed increases, the governor weight moves outwards centrifugally to a stop in the governor body, when it can move no further. When this occurs, a spring (A) located between the weight and the governor valve becomes effective. The constant force of this spring then combines, with the centrifugal force of the governor valve, the total then being

opposed by governor pressure, thus rendering this pressure less sensitive to output shaft speed variations.

The governor thus provides two distinct phases of regulation, the first being used for accurate control of the low speed shift points.

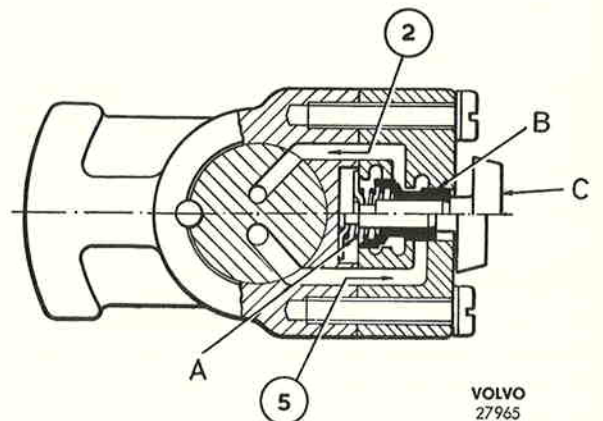

Fig. 15. Governor.

- | | |
|-----------|--------------------|
| A. Spring | C. Governor weight |
| B. Valve | |

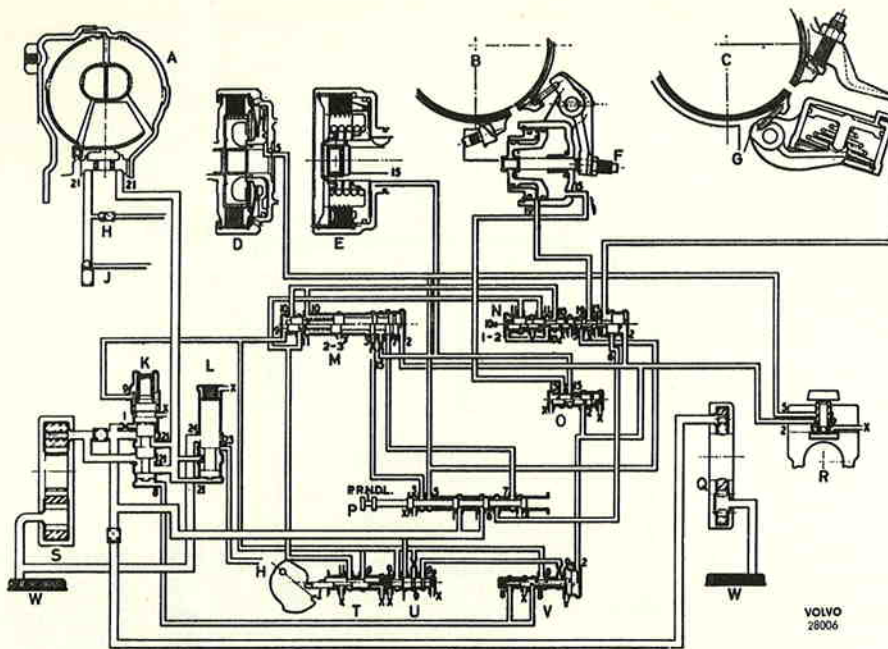

Fig. 16. Hydraulic circuits.

- | | | |
|---------------------------|--------------------------------|--------------------|
| A. Converter | J. Return line | R. Governor |
| B. Front brake band | K. Primary regulator valve | S. Front pump |
| C. Rear brake band | L. Secondary regulator valve | T. Downshift valve |
| D. Front clutch | M. 2—3 shift valve | U. Throttle valve |
| E. Rear clutch | N. 1—2 shift valve | V. Modulator valve |
| F. Front servo | O. Servo orifice control valve | W. Strainer |
| G. Rear servo | P. Manual control valve | |
| H. Lubrication ball valve | Q. Rear pump | |

CONTROL SYSTEM

The line and converter pressures are controlled by the primary and secondary regulator valves, the former operating in conjunction with throttle pressure acting upon the spring end, and modulated throttle pressure acting on the opposite end.

Shift control is provided by the 1—2 and 2—3 shift valves, which are operated by governor pressure, throttle pressure and line pressure.

Manual control is provided by the manual control valve which, according to the position of the selector, directs fluid to or provides an exhaust for the clutch and servo pistons.

For ease of reference, all hydraulic circuits are identified by numbers. The numbers in brackets in the following description refer to the line numbers, see Figs. 14—23.

Primary regulator valve

This valve regulates front pump pressure during idling, reversing and at low vehicle speeds, and rear pump pressure when, as a result of increased vehicle speed, the rear pump becomes effective. Rear pump regulation occurs when rear pump pressure exceeds front pump regulated pressure. This pressure differential opens the rear pump check valve allowing

rear pump fluid to flow to the primary regulator valve and supply the line pressure requirements. Front pump pressure is then no longer regulated by the primary regulator valve but flows through this to the secondary regulator valve.

Line pressure (1), operating on a small area of the valve, can be decreased by modulated throttle pressure (8) operating on one end of the valve. These forces are opposed by the primary regulator valve spring and throttle pressure (9) operating on the spring end of the valve. The line pressure thus produced varies with the accelerator position as well as vehicle speed and provides the correct clutch and brake capacity under all operating conditions. This line pressure (1) is directed to the manual valve and throttle valve.

Secondary regulator valve

This is a regulating valve which controls the values of converter pressure (21) and lubrication (23) for the components in the rear of the transmission case. Converter pressure operating on one end of the valve is opposed by spring force on the other end. When the front pump capacity is increased due to increased engine speed, the valve moves to open a port giving access to the suction side of the front

pump. Thus at high speed excess front pump output is directed back to minimize pumping losses.

Downshift valve and throttle valve

The downshift valve is connected to the carburetor linkage via a cable-actuated cam. Movement of the downshift valve compresses the throttle valve spring located between the downshift valve and the throttle valve. This spring is opposed by the throttle return spring, combined with throttle pressure (9) acting at low vehicle speed on one area of this regulating valve, and at higher vehicle speeds on two areas (9 and 9a). Thus a throttle pressure is produced that is related to both engine torque and vehicle speed. This pressure (9) is directed to the spring end of the primary regulator valve. The line pressure thus depends on the throttle pressure, providing correct clutch and brake band capacities and appropriate shift quality under all operating conditions.

Full movement of the downshift valve directs throttle pressure (11) to certain areas on the shift valves whereby upshifts or downshifts 3—2 and 3—1 respectively are obtained at pre-set maximum vehicle speeds.

Throttle pressure (9) is also directed to the 2—3 shift valve plunger which at part throttle opening reduces the value of throttle pressure by a fixed amount. This reduced pressure is directed to the 1—2 and 2—3 shift valves to render the low speed shift points less sensitive to throttle pressure and, therefore, accelerator position.

Modulator plug and valve

The modulator plug is a regulating valve that reduces throttle pressure (9) by a fixed amount. This modulated pressure (8) operating on the spring end of the plug and assisted by the modulator valve spring, is opposed by throttle pressure (9) operating on the opposite end. Modulated throttle pressure (8) is directed to the primary regulator valves to vary the rate of increase of line pressure relative to throttle pressure.

The modulator valve is a shuttle valve. Governor pressure operating on the large end is opposed by the modulator valve spring. As governor pressure rises, the valve moves, preventing the plug from regulating, and modulated throttle pressure (8) then becomes equal to throttle pressure (9). Moreover this movement directs throttle pressure to a second area of the throttle valve opposing throttle valve spring force. This arrangement permits high throttle and line pressures under full and partial throttle conditions, with a reduction in these pressures after "cut-back".

Servo orifice control valve

A common line (15) supplies fluid to, or exhaust fluid from, the rear clutch and the release area of the front servo to effect the 2—3 and 3—2 shift.

The servo orifice control valve is interposed in the front servo release circuit. Governor pressure (2) operating on an area of the valve is opposed by the valve spring. At a 2—3 shift with low governor pressure (i.e. low vehicle speed), fluid passes without restriction to the release side of the front servo system. At higher speeds, however, the valve moves and fluid is directed through an orifice to this side of the piston. During upshifts, with the servo orifice in circuit, the front band releases more slowly relative to rear clutch engagement, thus avoiding "run-up" during the transition from 2 to 3. During downshifts, the orifice in circuit ensures that the front band does not engage before the rear clutch releases, thus avoiding "tie-up" on the 3—2 shift.

The servo orifice control valve, therefore, affects the relationship between the rear clutch and front brake band and provides correct shift timing under all operating conditions.

1—2 shift valve

This operates when the selector lever is in "D". In 1st gear, governor pressure (2) operates on the large end of the valve. The governor pressure is opposed by the line pressure (5), the spring and reduced throttle pressure (10—10a). When governor pressure exceeds these opposing forces, the valve moves to the 2nd gear position and line pressure (5) is directed to the apply side of the front servo piston (19). The movement also results in an area of the valve being no longer subjected to line pressure (5). This allows the 2—1 downshift to occur at a lower speed than the 1—2 upshift. When the governor pressure is lower than the spring force combined with the throttle pressure, the valve moves to the 1st gear position and the apply side of the front servo (19) is opened to exhaust.

In "L" position also with low governor pressure, the valve moves to the 1st gear position; line pressure (6) thus directed to the rear servo (13) latches the valve hydraulically in the 1st gear position, preventing an upshift.

2—3 shift valve

The plunger in this shift valve reduces the value of throttle pressure (9) by a fixed amount and is therefore inoperative when throttle pressure is below this fixed amount. Throttle pressure (9), operating on one end of the plunger, is opposed by this reduced throttle pressure (10) and the 2—3 shift valve spring

located between the plunger and valve. This reduced pressure is directed to the 2—3 shift valve and the 1—2 shift plunger as described under "Downshift and throttle valve".

The 2—3 shift valve is a shuttle valve. In the 2nd gear position, and before the plunger begins regulating, governor pressure (2) operating on the large end of the valve is opposed by line pressure (3) operating on an area of this valve, as well as the 2—3 shift valve spring. Once the plunger begins regulating, the governor pressure (2) is opposed by the line pressure (3), the reduced throttle pressure (10) and the throttle pressure (9). This last force is relayed to the 2—3 shift valve by the valve spring.

Movement of the shift valve to the 3rd gear position directs fluid via the circuit (15) to the rear clutch and, via the servo orifice control valve, to the release side of the front servo. This pressure causes the rear clutch to be applied. Moreover, because the release area of the front servo is larger than the apply area, it causes the front band to be released. The movement also results in an area of the valve being no longer subjected to line pressure (3), and that the plunger in the valve, which is forced to the end of the valve bore by the spring, is not affected by any pressure. In this way reduced throttle pressure (10) is replaced by throttle pressure (9). This change in forces causes the 3—2 shift point to occur at a lower governor pressure (i.e. lower vehicle speed) than the 2—3 upshift.

When the manual control valve is moved to "L", line pressure (15) is exhausted since the line (3) has access to the oil pan. The circuit (7) at the opposite end of the manual control valve is also open. This inevitably results in an immediate downshift to 2nd gear regardless of the position of the 2—3 shift valve. In reverse, line pressure (7) is directed to the rear clutch and front servo release (15).

Manual control valve

This valve, which is actuated by the movement of the selector lever, directs line pressure to, or exhausts it from, the appropriate valves or components in accordance with control requirements.

Park

When the selector lever is moved to "P" the parking pawl is mechanically engaged with the externally toothed ring gear on the driven shaft, effectively immobilizing the vehicle. In this position no fluid is directed to the front clutch or 2—3 shift valve for the rear clutch, so that the gear set is disconnected from the converter and no engine power is transmitted to

the rear wheels. Due to the arrangement of the manual control valve lands, line pressure (6) is directed to the rear servo (13), which from a functional point of view has no significance.

Reverse

Line pressure (6) is directed to the rear servo (13) via the 1—2 shift valve and also (7) to the rear clutch (15) via the 2—3 shift valve. No pressure is directed to the governor.

Neutral

Line pressure is cut off from the clutches and servos which are also exhausted since the circuits (3) and (5) have access to the oil sump via the manual control valve (x). The gear set is therefore disconnected from the converter and no engine power is transmitted to the rear wheels.

Drive

Line pressure (5) is directed to the front clutch, governor and 1—2 shift valve. Line pressure is also directed to the 2—3 shift valve.

Lock-up

Line pressure (5) is directed to the front clutch, governor and 1—2 shift valve, but not to the 2—3 shift valve. In this position, therefore, upshifts to 3rd gear are excluded.

When in 1st gear, line pressure (6) is directed to a differential area of the 1—2 shift valve to lock it in 1st position, and thence to the rear servo.

FUNCTION

Since the control system is affected by both the selector lever position, the speed of the car and the position of the accelerator pedal, many different operating conditions occur. In order to make it easier to understand how the control system operates, we describe below a working cycle in each gear position and gear.

Operation in "N", see Fig. 17

With the engine running, the front pump check valve is open and the rear pump check valve closes due to absence of rear pump pressure.

The primary regulator valve regulates line pressure (1) which is directed to the manual valve and throttle valve. It also permits fluid to reach the secondary regulator valve.

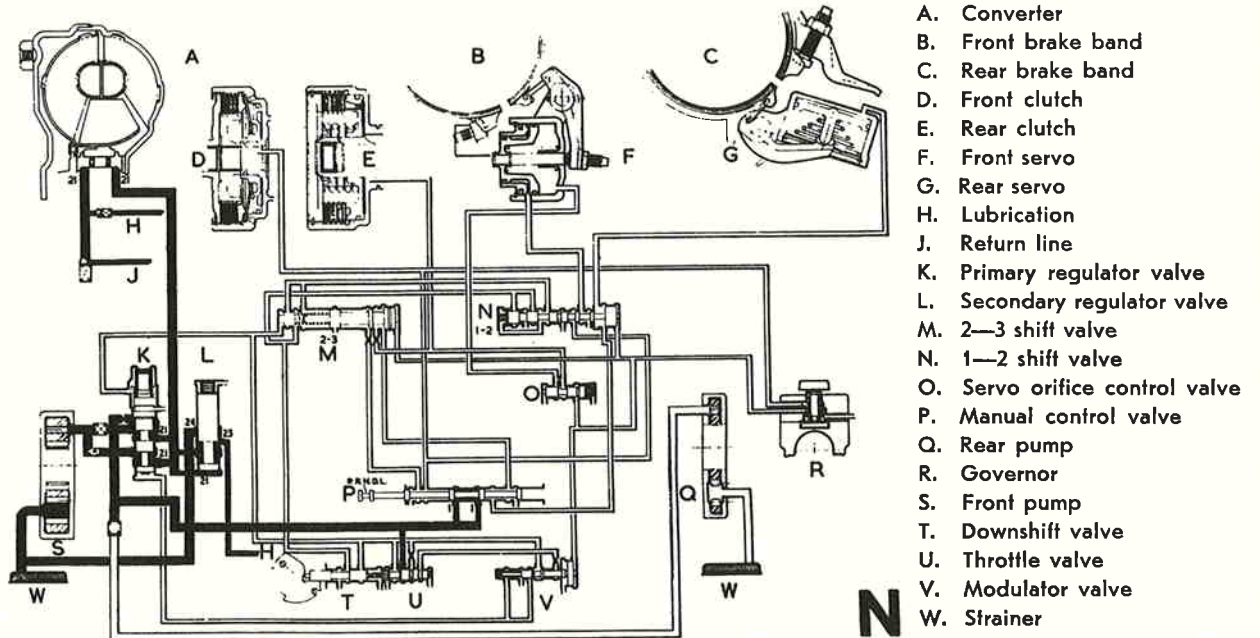

- A. Converter
- B. Front brake band
- C. Rear brake band
- D. Front clutch
- E. Rear clutch
- F. Front servo
- G. Rear servo
- H. Lubrication
- J. Return line
- K. Primary regulator valve
- L. Secondary regulator valve
- M. 2—3 shift valve
- N. 1—2 shift valve
- O. Servo orifice control valve
- P. Manual control valve
- Q. Rear pump
- R. Governor
- S. Front pump
- T. Downshift valve
- U. Throttle valve
- V. Modulator valve
- W. Strainer

VOLVO
28007

Fig. 17. Operation in "N".

The secondary regulator valve regulates pressure to the converter and lubrication of the front end of the gear train (21). Identical pressure (23) is directed to the rear end of the gear train for lubricating this. The surplus flow (24) is directed back to the inlet of the front pump.

Operation in "P", see Fig. 18

An internal linkage from the manual control valve detent lever engages the parking pawl with teeth formed on the driven shaft ring gear.

With the engine running, the operation of the hydraulic system is identical to "N" except that the

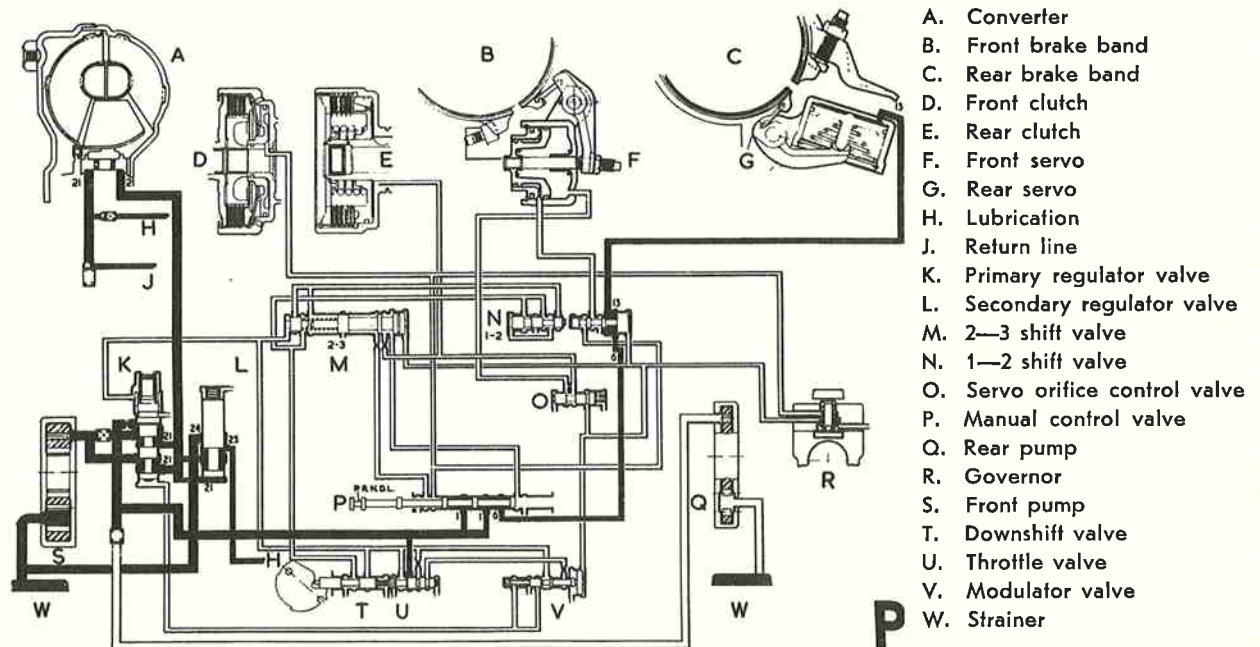

- A. Converter
- B. Front brake band
- C. Rear brake band
- D. Front clutch
- E. Rear clutch
- F. Front servo
- G. Rear servo
- H. Lubrication
- J. Return line
- K. Primary regulator valve
- L. Secondary regulator valve
- M. 2—3 shift valve
- N. 1—2 shift valve
- O. Servo orifice control valve
- P. Manual control valve
- Q. Rear pump
- R. Governor
- S. Front pump
- T. Downshift valve
- U. Throttle valve
- V. Modulator valve
- W. Strainer

VOLVO
28008

Fig. 18. Operation in "P".

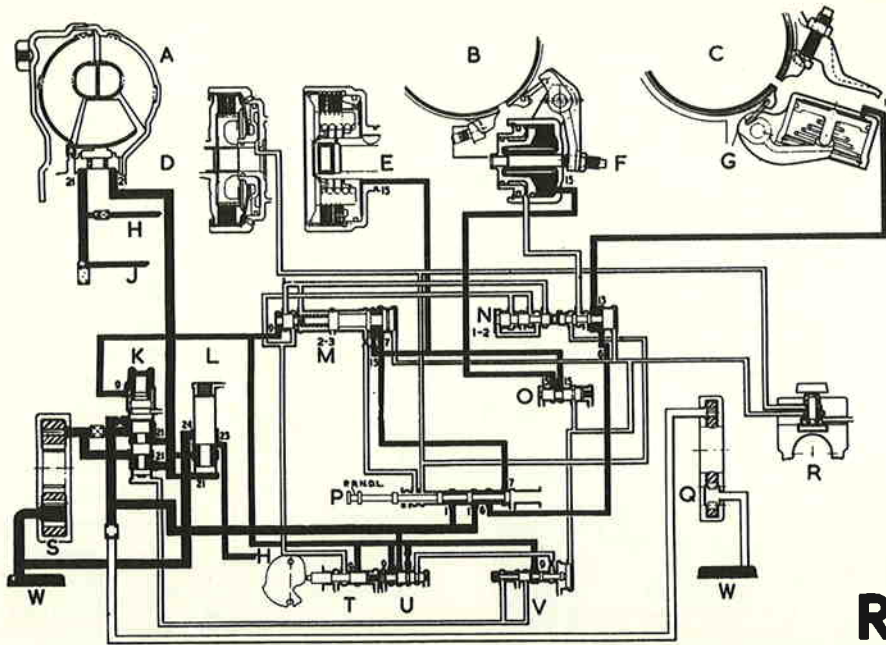

Fig. 19. Operation in "R".

manual valve directs line pressure (6) to the rear servo (13). This arrangement originates in the design of the manual control valve on which, for simplicity, three of the lands serve to control both the "L" and "P" selector positions. The application of the rear brake band does not perform any function in "P".

Operation in "R", see Fig. 19

Control of the line pressure takes place as in "P" or "N", but when the accelerator pedal is depressed, throttle pressure (9) is directed to the spring end of the primary regulator valve, thus increasing line pressure (1) in accordance with torque capacity requirements. The manual valve directs line pressure (6) through the 1—2 shift valve to the rear servo (13) and line pressure (7) through the 2—3 shift valve to the rear clutch and front servo release (15). Due to absence of governor pressure, the shift valves and servo orifice control valve perform no function in this selector position. The fluid passages (13) and (15) of the other manual valve positions are utilized in "R" to simplify the hydraulic circuit.

Operation in "D 1", see Fig. 20

Fluid pressure from the front and/or rear pump is controlled as in "R", but with the throttle valve in the full throttle position as shown in Fig. 20, a modulator throttle pressure regulated by the valve plunger will be obtained. This pressure acts upon the primary

regulator valve opposing throttle pressure (9), thus modulating line pressure in order to give reliable and smooth shifting under all driving conditions. The manual valve directs line pressure (5) to the front clutch, governor feed and 1—2 shift valve for the subsequent 1—2 shift. Line pressure (3) reaches the 2—3 shift valve for the subsequent 2—3 shift. The front clutch applied in conjunction with the one-way clutch permits the car to move off from rest in 1st gear.

Operation in "D 2", see Fig. 21

The primary regulator valve regulates the pressure from the rear pump, the front pump providing torque converter (21) and gearbox (21, 23) lubrication requirements. Throttle pressure (8, 9) acts upon the primary regulator valve as in "D 1". Shift control is provided by the 1—2 shift valve moving under the influence of governor pressure (2), opposed by spring force and throttle pressure (11). When the governor pressure (2) is high enough, the valve will move to 2nd gear position and line pressure (5) will flow to the apply side of the front servo (19). The front band is thus applied and, in conjunction with the front clutch, provides 2nd gear. With the downshift valve in the forced throttle position as illustrated, forced throttle pressure (11) acts upon the 1—2 shift valves, thus further delaying upshifts or providing a 2—1 downshift at speeds where there is little governor pressure (2).

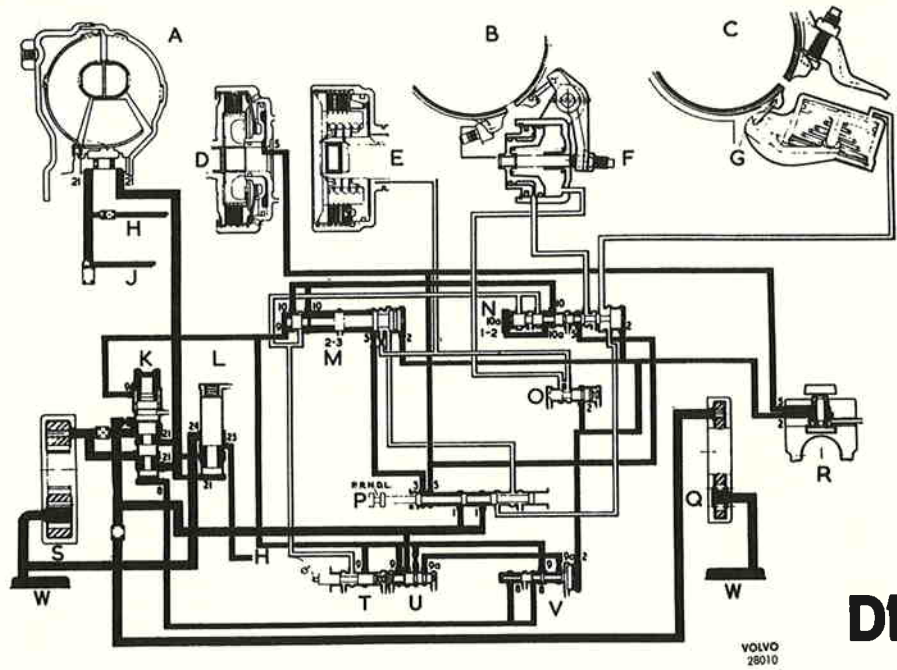

Fig. 20. Operation in 1st gear, position "D".

- | | | |
|---------------------|--------------------------------|--------------------|
| A. Converter | J. Return line | R. Governor |
| B. Front brake band | K. Primary regulator valve | S. Front pump |
| C. Rear brake band | L. Secondary regulator valve | T. Downshift valve |
| D. Front clutch | M. 2—3 shift valve | U. Throttle valve |
| E. Rear clutch | N. 1—2 shift valve | V. Modulator valve |
| F. Front servo | O. Servo orifice control valve | W. Strainer |
| G. Rear servo | P. Manual control valve | |
| H. Lubrication | Q. Rear pump | |

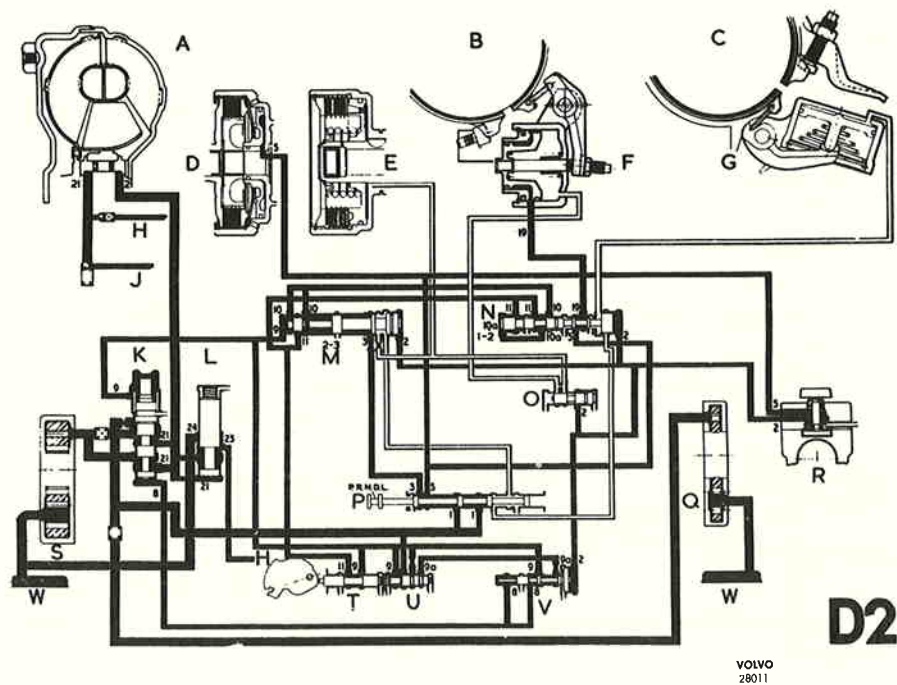
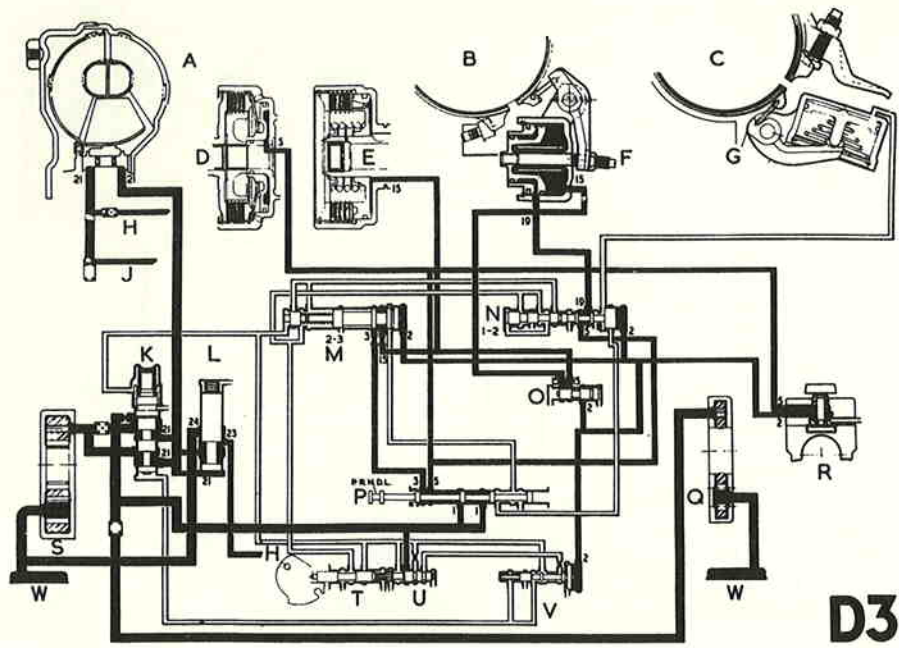

Fig. 21. Operation in 2nd gear, position "D".



VOLVO
28012

Fig. 22. Operation in 3rd gear, position "D".

- | | | |
|---------------------|--------------------------------|--------------------|
| A. Converter | J. Return line | R. Governor |
| B. Front brake band | K. Primary regulator valve | S. Front pump |
| C. Rear brake band | L. Secondary regulator valve | T. Downshift valve |
| D. Front clutch | M. 2-3 shift valve | U. Throttle valve |
| E. Rear clutch | N. 1-2 shift valve | V. Modulator valve |
| F. Front servo | O. Servo orifice control valve | W. Strainer |
| G. Rear servo | P. Manual control valve | |
| H. Lubrication | Q. Rear pump | |

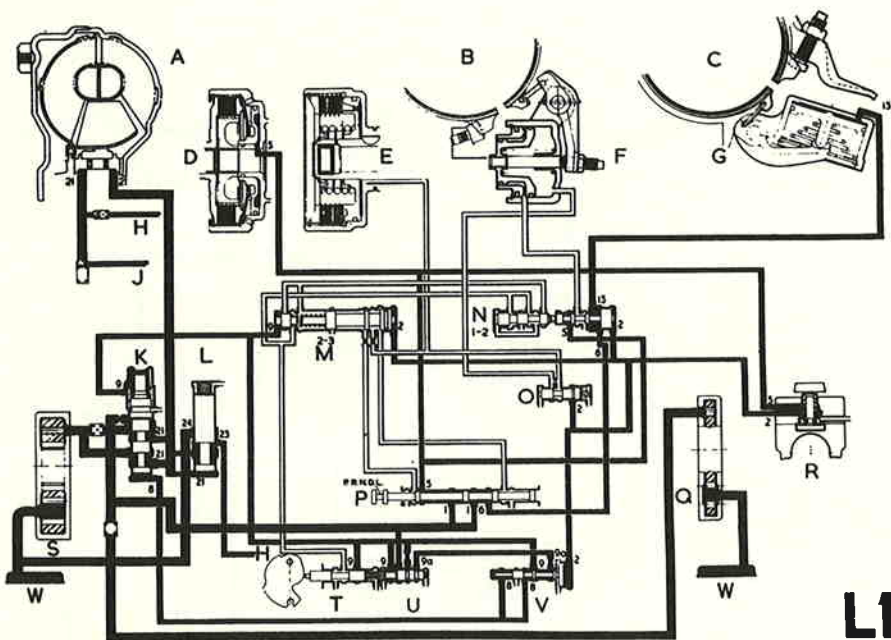

VOLVO
28013

Fig. 23. Operation in 1st gear, position "L".

Operation in "D 3", see Fig. 22

Pressure control is as in "D 2" except that in the throttle valve position shown (minimum throttle) no throttle pressure or modulated throttle pressure acts upon the two ends of the primary regulator valve. Shift control is provided by the 2—3 shift valve moving against spring force under the influence of governor pressure (2). This permits line pressure (3) to reach the rear clutch (15), and the release side of the front servo through the servo orifice control valve. When governor pressure (2) is apparent, the servo orifice valve closes, forcing line pressure through a 0.052" (1.3 mm) orifice which thus affects the relationship between rear clutch apply and front servo release in accordance with road speed.

Because the release side of the front servo has a larger area than the apply side, the front servo will disengage the band. The rear clutch now engaged in conjunction with the front clutch provides 3rd gear.

The absence of throttle pressure as mentioned above will cause the 2—3 shift valve to move early under influence of governor pressure, thus providing a low-speed 2—3 shift.

Operation in "L", see Fig. 23

Pressure control of the front and/or rear pump will be as in "D 1" at the same throttle valve position (full throttle) as illustrated.

The manual valve directs line pressure (5) to the front clutch, governor feed and 1—2 shift valve; it also directs line pressure (6) to the 1—2 shift valve. In the 1st gear condition illustrated, the 1—2 shift valve is latched hydraulically by line pressure (6) operating on so great an area. This is certainly opposed by the governor pressure (2) but this pressure is lower than the line pressure. The result is that line pressure (6) is open to the rear servo (13) and no upshift can occur. In the "L" position the manual control valve opens the circuit (7) to the sump thus exhausting the rear clutch and front servo release circuit (15) via the 2—3 shift valve. This causes a 3—2 downshift at whatever road speed the car has when the selector is moved to "L". In this condition governor pressure (2) will have moved the 1—2 shift valve to 2nd position; the result is that line pressure (6) is then blocked from the rear servo (13) but (5) is open to the apply side of the front servo (19) as in "D 2".

TABLE OF HYDRAULIC CIRCUITS

Circuit No.	Name of pressure	From	To	Theoretical pressure range		Remarks
				lb/sq.in.	kg/cm ²	
1*	Line pressure	Front and rear pump	Primary regulator valve Manual control valve Throttle valve	55—160—75	3.9—11.3—5.3	The only pressure that can be measured
2	Governor pressure	Governor	Modulator valve 1—2 shift valve 2—3 shift valve Servo orifice control valve	0—70	0—4.9	According to road speed
3	Directed line pressure	Manual control valve	2—3 shift valve	55—160—75	3.9—11.3—5.3	In "D"
5	Directed line pressure	Manual control valve	Front clutch and governor feed 1—2 shift valve	55—160—75	3.9—11.3—5.3	In "L" and "D"
6	Directed line pressure	Manual control valve	1—2 shift valve	55—160—75	3.9—11.3—5.3	In "L", "D", "R" and "P"
7	Directed line pressure	Manual control valve	2—3 shift valve	55—160—75	3.9—11.3—5.3	In "R" and "P"
8	Modulated throttle pressure	Modulator valve	Primary regulator valve	0—135—68	0—9.5—4.7	
9	Throttle pressure	Throttle valve	Modulator valve Primary regulator valve (spring end) 2—3 shift valve and shift valve plug	0—135—68	0—9.5—4.7	
9a	Throttle pressure controlled by modulator valve	Modulator valve	Throttle valve	0—135	0—9.5	Doubles throttle pressure before cut-back and increases line pressure under part-throttle acceleration
10	Shift valve plunger pressure	Shift valve plunger	2—3 shift valve 1—2 shift valve	0—68	0—4.7	
10a	Shift valve plunger pressure	Shift valve plunger	1—2 shift valve	0—68	0—4.7	In 1st gear only
11	Forced throttle pressure	Downshift valve	1—2 shift valve 2—3 shift valve	135	9.5	
13	Line pressure	1—2 shift valve	Rear servo apply	55—160—75	3.9—11.3—5.3	
15	Line pressure	2—3 shift valve	Rear clutch and front servo release	55—160—75	3.9—11.3—5.3	Front servo release through servo orifice or valve
19	Line pressure	1—2 shift valve	Front servo apply	55—160—75	3.9—11.3—5.3	
21	Converter pressure	Primary regulator valve	Secondary regulator valve and converter	18—25	1.25—1.75	
23	Lubrication pressure	Secondary regulator valve	Front pump suction	18—25	1.25—1.75	
24	Exhaust	Secondary regulator valve	Front pump suction			

NOTE: Where a pressure range consists of three figures, the first value represents idling speed, the second forced throttle before cut-back, and the third forced throttle after cut-back.

MAINTENANCE AND REPAIR INSTRUCTIONS

When carrying out any work on the vehicle, the selector lever should be in position "P".

Provided the transmission is operating satisfactorily, the car may be towed in position "N". The fluid level must be correct. If the transmission is inoperative, the propeller shaft should be disconnected before starting towing.

The control system of the automatic transmission is manufactured with the same degree of precision and accurate fits as the injection equipment of a Diesel engine. Fluid circulates through the converter, transmission gearbox and control system. It is therefore necessary to observe the utmost cleanliness when carrying out any work on the transmission.

WORK WHICH CAN BE CARRIED OUT WITHOUT REMOVING THE TRANSMISSION

Checking the fluid level

The fluid level should be checked every 3000 miles (5000 km).

The filling pipe with dipstick is located in front of the bulkhead on the right-hand side of the engine.

When checking, the transmission should be at normal operating temperature which is obtained after driving for about 5 miles (8—10 km). The car should be on a level surface. Move the selector lever to "P" and allow the engine to idle for two minutes. With the engine still idling in "P", wipe the dipstick with a non-fluffy rag, clean paper or chamios leather. Push down the dipstick, pull it up and read off the fluid level, see Fig. 24 if necessary, add fluid to bring the level to the "max." mark. Do not fill up over the "max." mark as otherwise the transmission can overheat. The difference between the "min." and "max." marks on the dipstick is 1 Imp. pint (0.5 litre). Use an approved Type A Suffix A Automatic Transmission Fluid for filling up.

When filling up with oil during cold weather, for example, after having carried out repairs, the level should come 10 mm ($\frac{3}{8}$ ") below the "max." mark. The gearbox should then be run warm, after which the oil level is checked as described above.

If it is necessary to fill up with fluid frequently, this indicates leakage, which must be put right immediately.

Adjusting the selector controls

1. Disconnect the pull rod from the lever on the selector shaft. Set the selector lever to "N", see Fig. 25.

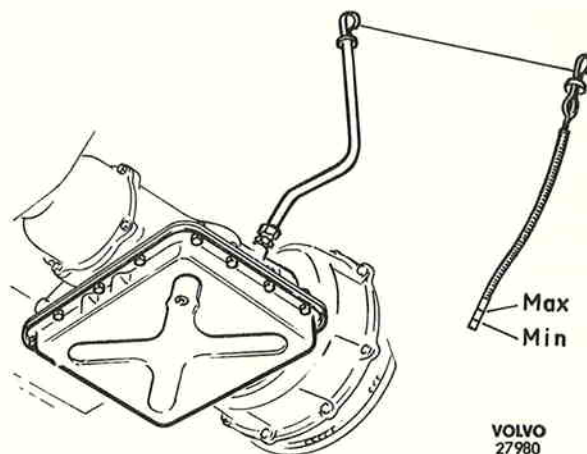

Fig. 24. Checking fluid level.

2. Set the lever on the transmission to the central position. Adjust the length of the pull rod so that the pin can be pushed easily through the yoke and lever.
3. Check the adjustment by moving the selector lever to the other positions.
4. Check that the pointer for the gear positions points correctly on the scale. If not, slacken the screws for the scale and move it sideways until the pointer indicates correctly.
5. Check that the output shaft is locked with the control lever in position "P".

Adjusting the downshift valve cable

Correct adjustment of this cable is most important for satisfactory operation of the transmission. There are three different methods. Adjust first in accordance with A, see Fig. 26.

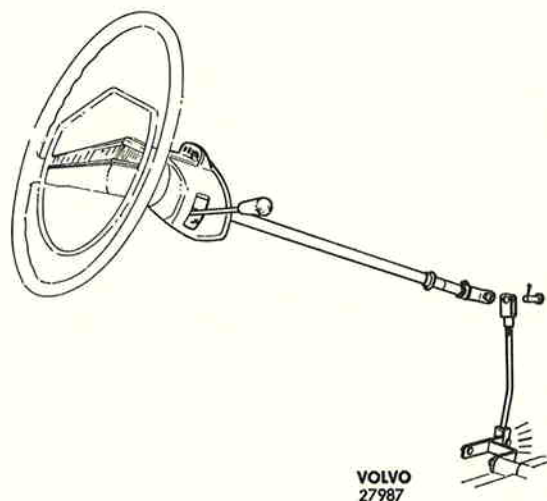

Fig. 25. Adjusting selector controls.

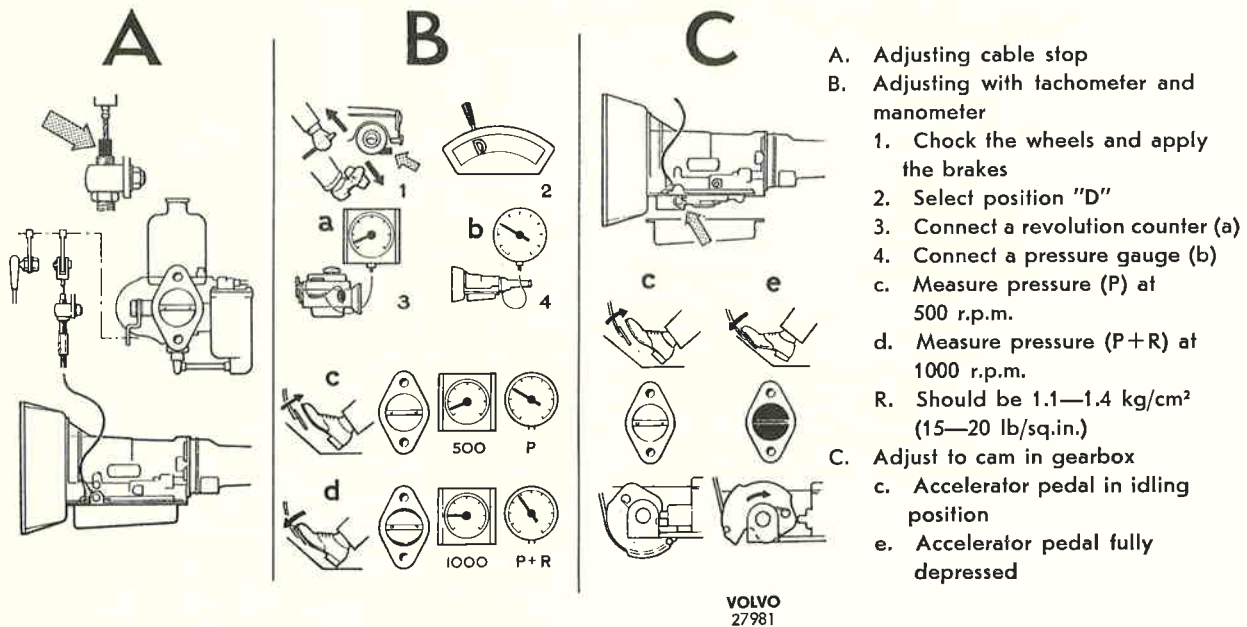

Fig. 26. Adjusting throttle cable.

- A. 1. Check that engine idling speed is correctly adjusted and that the inner cable and outer cable are correctly attached.
2. Screw up the outer cable abutment until it just contacts the crimped stop which is crimped onto the inner cable.
3. With the accelerator pedal fully depressed, check that:
- the carburetor lever is at the full open stop.
 - the line pressure at converter stall speed amounts to at least 160 lb./sq.in. (11 kg/cm²).
- B. If the cable stop has been damaged or moved, the cable must be adjusted as follows:
- Connect a tachometer to the engine and manometer to the transmission as shown in the figure.
 - Chock the wheels and apply the brakes. Start the engine and move the lever to "D". Read off the pressure at 500 and 1000 r.p.m. At 1000 r.p.m. the pressure should be 15—20 lb./sq.in. (1.1—1.4 kg/cm²) higher than at 500 r.p.m. If the pressure rise is less than 15 lb./sq.in. (1.1 kg/cm²), the effective length of the outer cable should be increased by means of the adjuster. Conversely, if the rise is more than 20 lb./sq.in. (1.4 kg/cm²) the effective length of the outer cable should be decreased.
- C. If a new cable has to be fitted, the transmission oil pan must be removed. In this event it is often simpler to adjust the cable by observing the

movement of the cam in relation to accelerator pedal movement as follows:

- With the accelerator pedal fully released and the carburetor lever at the idling stop, the heel of the cam should contact the full diameter of the downshift valve, with all the slack of the inner cable taken up.
- With the accelerator pedal fully depressed and the carburetor lever at the full open stop, the constant radius area of the cam should be the point of contact with the downshift valve.

- Note:**
- The cable is pre-lubricated with silicon or molybdenum disulphide lubricant and must not be oiled.
 - Ensure that at all times the outer cable is correctly located in the adjuster.

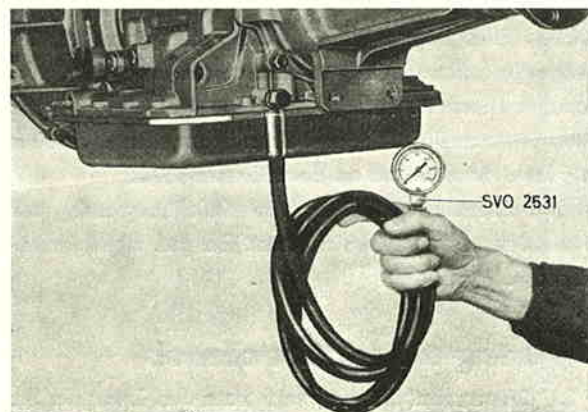

Fig. 27. Connecting manometer.

VOLVO
400 062

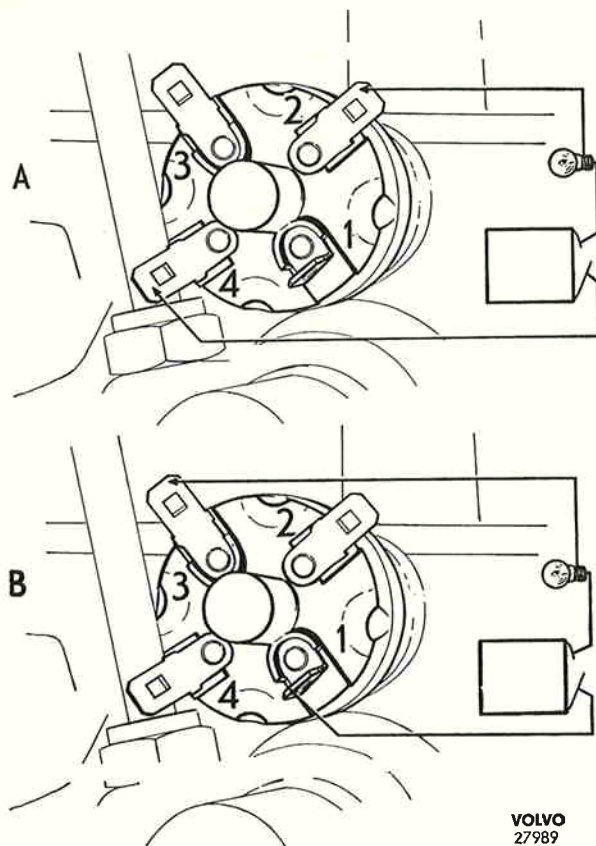

Fig. 28. Adjusting starter inhibitor.

- A. Bulb connected to reversing light contacts
 B. Bulb connected to starter inhibitor contacts

Adjusting the starter inhibitor switch

The starter inhibitor switch has two terminals for the starter inhibitor circuit, the function of which is to prevent the engine from being started with the selector in any other position than "N" or "P". There are also two terminals for the reversing light. It is very important that this switch is correctly adjusted, since if the engine can be started in any of the driving positions, the car can easily be set in motion unintentionally and cause an accident. The switch is adjusted as follows:

1. First check that the selector control is correctly adjusted. Move the selector to "D".
2. Slacken the locknut for the switch with the help of the special spanner. Screw out the switch until it is only held by a couple of threads.
3. Connect a control lamp to the reversing light terminals as shown in Fig. 28 "A". Screw in the switch until the lamp goes out. Mark this position on the housing and switch with a pencil.
4. Connect the control lamp to both the other terminals, Fig. 28 "B". Screw in the switch until the lamp lights again and then mark the switch again. Then screw back the switch to halfway between both the marks. Lock with the locknut. Connect the leads.

5. Apply the brakes and chock the wheels. Check that the engine can only be started with the selector lever in "N" or "P". Move the selector lever to "R" and check that the reversing light lights up when the lighting switch is switched on.

Adjusting the front brake band

1. Before lifting up the car, disconnect the throttle cable and outer casing on the throttle control. Remove the throttle control and take off the air cleaner. Drain off the coolant and disconnect the upper radiator hose and the hoses between the engine and heater. Disconnect the exhaust manifold at the flange. Jack up and place blocks under the car.
2. Support under the converter case with a jack. Disconnect the exhaust pipe at the gearbox. Disconnect the propeller shaft and rear mounting and lower the transmission.
3. Drain out the fluid into an absolutely clean container. Remove the oil pan. Slacken the locknut for the adjusting screw of the front brake band. Place the spacer between the adjusting screw and the servo piston pin, see Fig. 29. Tighten the servo adjusting screw with a torque wrench and special tool to 10 lb.in. (11.5 kgcm).
4. Tighten the locknut and remove the gauge block. Fit the oil pan and exhaust manifold. Fill up with fluid.

Adjusting the rear brake band

When adjusting this band in the car, on early production cars the gearbox must be released and lowered as described in points 1 and 2 under "Adjusting the front brake band". On cars with body numbers as shown below, a hole has been introduced in the body tunnel, which is sealed with a rubber plug. On these cars it is only necessary to lift up the

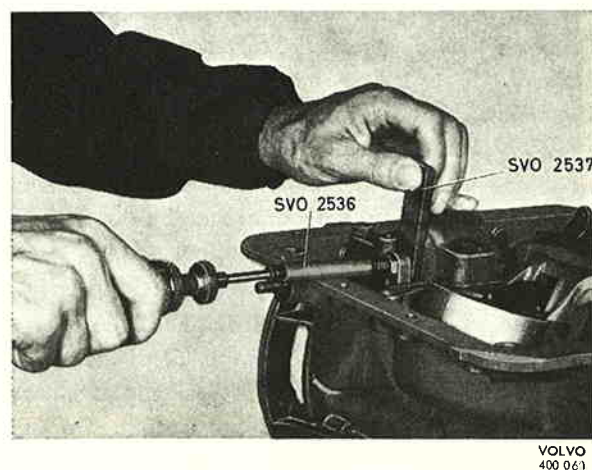
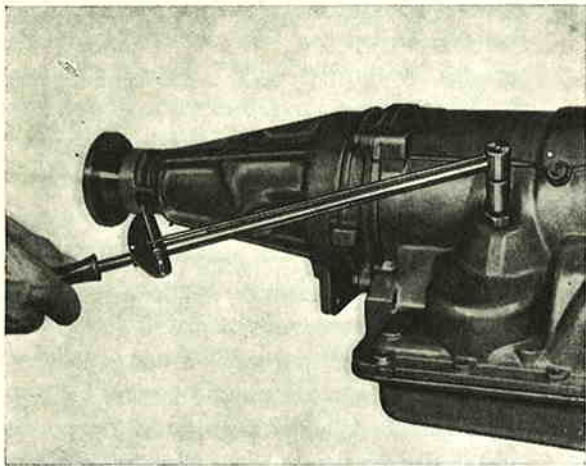

Fig. 29. Adjusting front brake band.



VOLVO
27991

Fig. 30. Adjusting rear brake band.

rubber mat and remove the rubber plug in order for the adjusting device to be accessible. This modification has been introduced on the following body numbers:

- P 120, 2-door body number 93547 onwards
- P 120, 4-door body number 170430 onwards.

Adjusting is carried out as follows:

1. Slacken the locknut for the adjusting screw.
2. Use the special socket and connect the torque wrench to the adjusting screw, see Fig. 30. Tighten the screw to 10 lb.ft. (1.4 kgm). Back off the adjusting screw one turn.
3. Tighten the locknut and fit any parts which have been removed.

Air pressure checks

Air pressure checks can be made on the gearbox assembly to determine whether the clutches and brake bands are operating. These checks can be made with the transmission in the car or on the bench. In either event, drain the fluid from the gearbox and remove the oil pan as well as the valve bodies assembly with oil tubes. The air used must be clean and dry.

If the clutch and bands operate satisfactorily with air pressure, faulty operation of the transmission must be due to malfunction of the hydraulic control system. The valve bodies assembly must then be dismantled, cleaned, inspected and re-assembled.

FRONT CLUTCH AND GOVERNOR FEED "A"

Apply air pressure to the passage (5) of the transmission case rear wall, see Fig. 31. Listen for a thump, indicating that the clutch is functioning. On the bench, also verify by rotating the input shaft with air pressure applied.

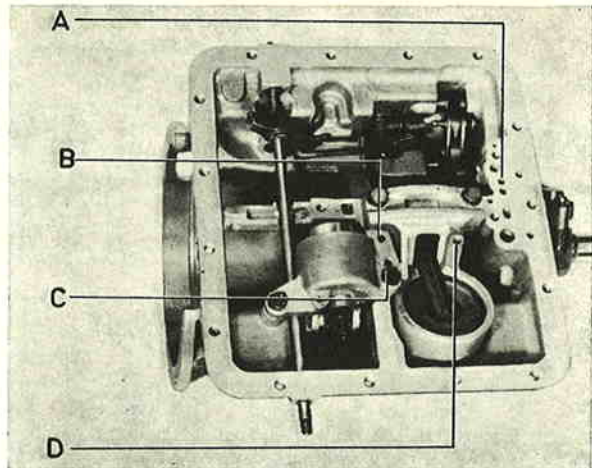

VOLVO
27966

Fig. 31. Functioning test with compressed air.

- | | |
|---------------------|----------------------------|
| A. Front clutch (5) | C. Front servo application |
| B. Rear clutch (15) | D. Rear servo |

If the extension housing has been removed, rotate the output shaft so that the governor weight will be at the bottom of the assembly. Verify that the weight moves inwards with air pressure applied.

REAR CLUTCH "B"

Apply air pressure to the passage (15) of the transmission case web. On the bench, verify by turning the input shaft that the clutch is functioning. Keep air pressure applied for several seconds to check for leaks. Then listen for a thump indicating that the clutch is releasing when the air pressure is removed.

FRONT SERVO "C"

Apply air pressure to the hole immediately adjacent to the rear retaining bolt. Observe the movement of the piston pin.

REAR SERVO "D"

Apply air pressure to the hole on the servo body. Observe the movement of the servo lever.

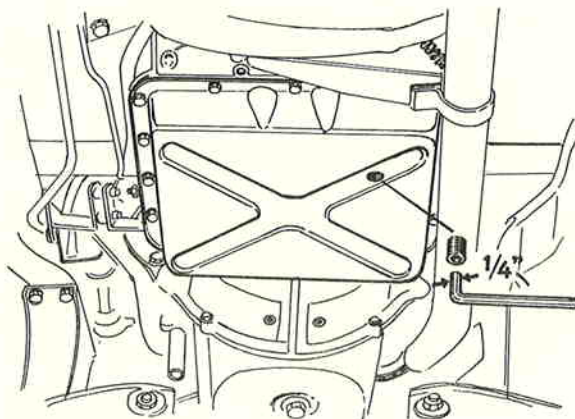

VOLVO
27982

Fig. 32. Oil drain plug.

REMOVING TRANSMISSION FROM CAR

Gearbox

1. Before lifting up the car, disconnect the throttle cable and outer casing on the throttle control. Remove the throttle control and take off the air cleaner. Drain off the coolant and disconnect the upper radiator hose and the hoses between the engine and heater. Disconnect the exhaust manifold at the flange. Jack up and place blocks under the car.
2. Drain out the oil into an absolutely clean container, see Fig. 32. Caution. The fluid can be very hot, causing scalding if it comes into contact with the skin.
3. Disconnect the propeller shaft from the gearbox flange. Disconnect the exhaust pipe at the flange. Remove the speedometer cable and selector linkage from the gearbox. Also remove the filler tube. Disconnect the leads for the starter inhibitor and reversing light.
4. Place a jack under the converter housing to take the weight. Disconnect the rear mounting of the transmission. Lower the transmission and engine.
5. Place a unit lift under the transmission. Remove the six bolts which retain the gearbox to the converter housing. Place a clean container under the transmission to catch the fluid which will run out of the converter when the gearbox is withdrawn. Withdraw the gearbox to the rear.

Converter

This description also applies when it is desired to remove the gearbox and converter together.

1. The various parts are removed in accordance with points 1—4 above, but the jack under the converter housing is removed and the engine supported in another manner, for example, with a block between the engine and bulkhead.

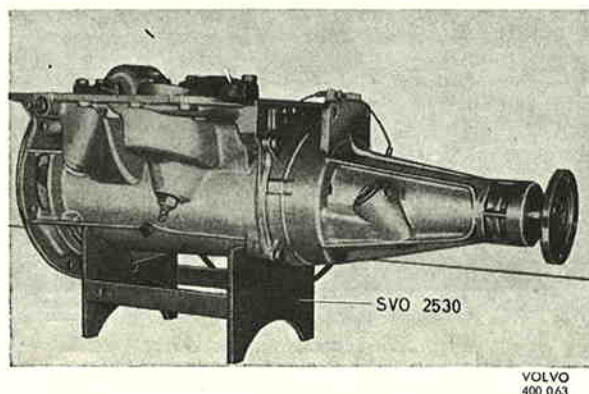

Fig. 33. Transmission on bench stand.

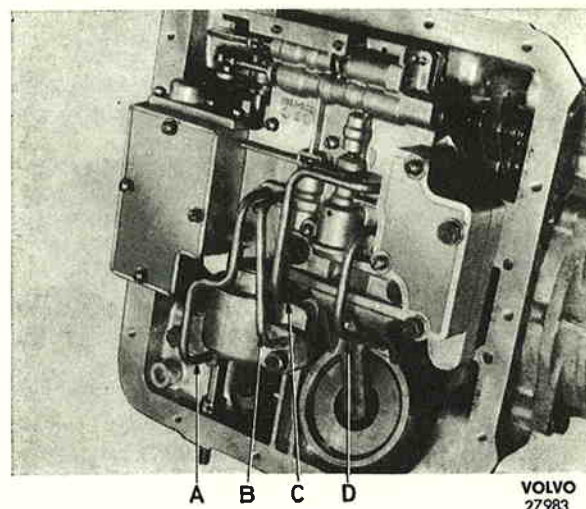

Fig. 34. Oil tubes.

- | | |
|----------------------------|----------------|
| A. Front servo release | C. Rear clutch |
| B. Front servo application | D. Rear servo |
2. Remove the plate on the front of the converter. Unscrew the bolts which retain the converter housing to the engine and withdraw the converter housing or gearbox respectively to the rear.
 3. Unscrew the four bolts and lock washers which retain the converter to the drive plate. Withdraw the converter to the rear.

DISMANTLING

As a general rule it is advisable only to dismantle those components requiring attention as indicated by road-testing or fault-tracing procedure. Prior to the removal of any components, the outside of the gearbox must be thoroughly washed down with paraffin (kerosene) or white spirit. A high standard of cleanliness is required when handling or storing components.

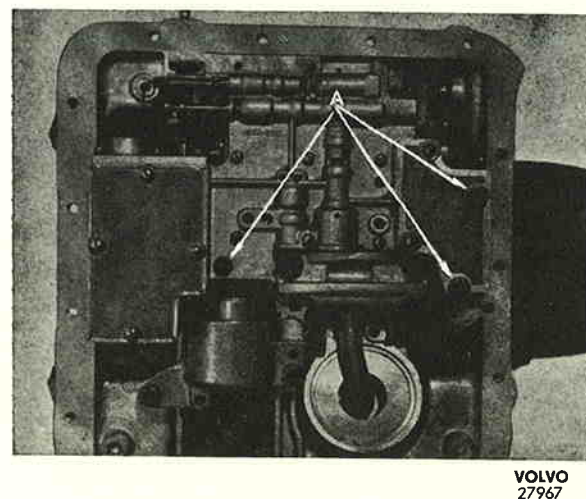
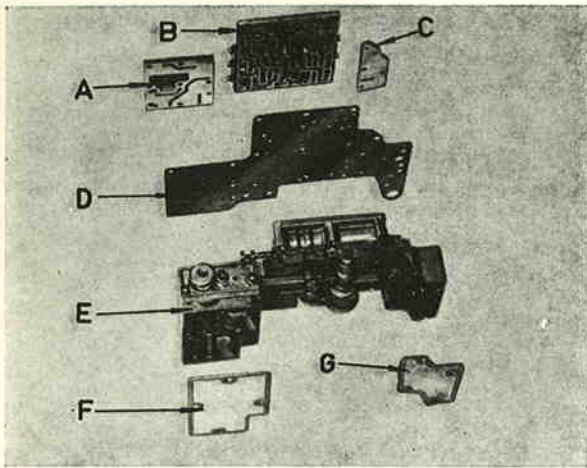

Fig. 35. Valve bodies assembly.

- A. Attaching screws



VOLVO
27968

Fig. 36. Main components of valve bodies assembly.

- A. Oil tube collector
- B. Upper valve body
- C. Governor line plate
- D. Separating plate
- E. Lower valve body
- F. Front pump strainer
- G. Rear pump strainer

When dismantling, the gearbox should be inverted and placed on the bench cradle as shown in Fig. 33, and special tools used as shown in the service tool list. Treat the various components with great care, particularly light-alloy parts. When the gearbox is to be completely dismantled, follow the procedure below.

1. If the converter housing is attached to the gearbox, remove the six bolts and withdraw the converter housing.
2. Unscrew the "Wedglok" screw for the drive flange on the output shaft. Pull out the drive flange and catch $\frac{3}{8}$ " plain washer. Loosen and withdraw the rear housing. Remove the speedometer gear.

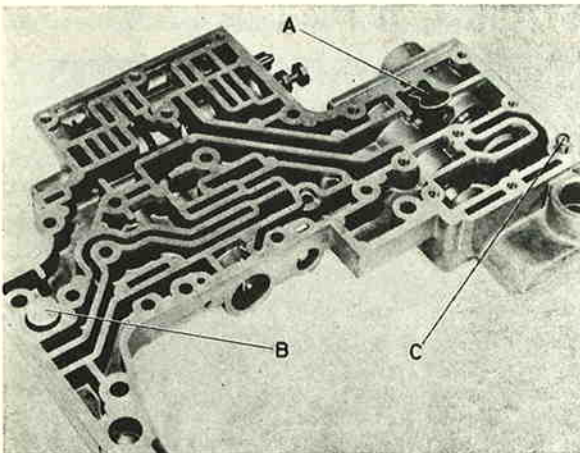

VOLVO
27969

Fig.37. Check valves in lower valve body.

- A. Front pump check valve
- B. Rear pump check valve
- C. Converter outlet check valve

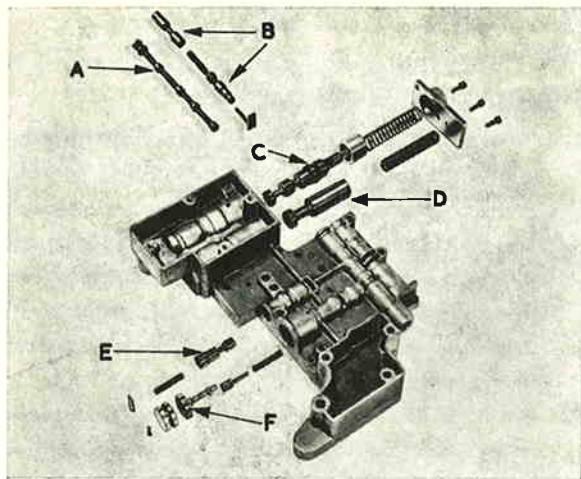

VOLVO
28001

Fig. 38. Lower valve body.

- A. Manual control valve
- B. Downshift and throttle valve
- C. Primary regulator valve
- D. Secondary regulator valve
- E. Servo orifice control valve
- F. Modulator valve

3. Unscrew the bolts for the oil pan and remove this. Lever out the oil tubes carefully as shown in Fig. 34.

The valve bodies assembly

Work on the whole assembly should preferably be carried out in a Diesel test-room or in a room with equal standards of cleanliness.

4. Disconnect the downshift valve cable from the downshift valve cam. Unscrew the three screws which retain the valve bodies assembly to the gearbox housing, see Fig. 35. Lift the valve bodies assembly straight up so that it releases from the oil tubes at the front end.

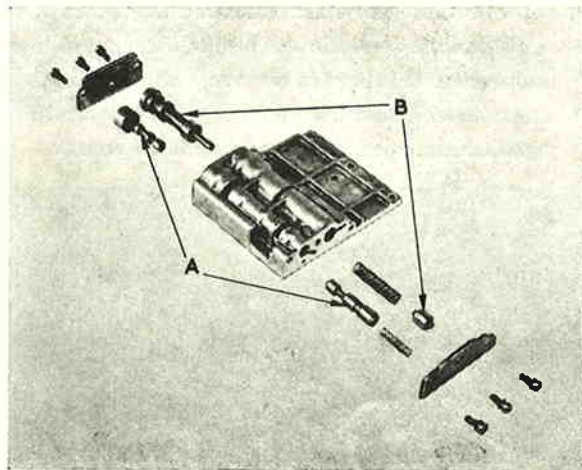

VOLVO
28002

Fig. 39. Upper valve body.

- A. 1—2 shift valve and plunger
- B. 2—3 shift valve and plunger

5. Unscrew the two screws for the bracket of the downshift valve cam.
6. Remove the two strainers for the front and rear pump respectively.
7. Unscrew from above the screws which retain the upper valve body. Turn the valve bodies assembly round and unscrew the other six screws from underneath.
8. Unscrew the eight screws which retain the oil tube collector.
9. Unscrew the four screws which retain the governor line plate. Note that two screws are under one of the strainers.
10. Remove the separating plate and then the check valves for the converter and front and rear pumps, see Fig. 37. Withdraw the manual control valve, see "A", Fig. 38.
11. Remove the stop for the throttle valve and the return spring. Then withdraw the downshift valve, spring and throttle valve, see Fig. 38.
12. Remove the dowel pin which retains the plug for the modulator valve. Then remove the plug, valve, plunger and spring.
13. Remove the stop for the servo orifice control valve and then the spring and valve.
14. From the manual valve side of the lower valve body, remove the following components: three screws, lower body end plate, primary regulator spring, primary regulator valve sleeve, primary regulator valve, secondary regulator valve spring and secondary regulator valve.
15. Remove the six screws and end plates from the upper valve body, see Fig. 39. Remove the following parts from the rear end of the body: shift valve 2—3, inner spring and plunger together with shift valve 1—2. The spring and plunger for shift valve 1—2 are removed in the other direction.

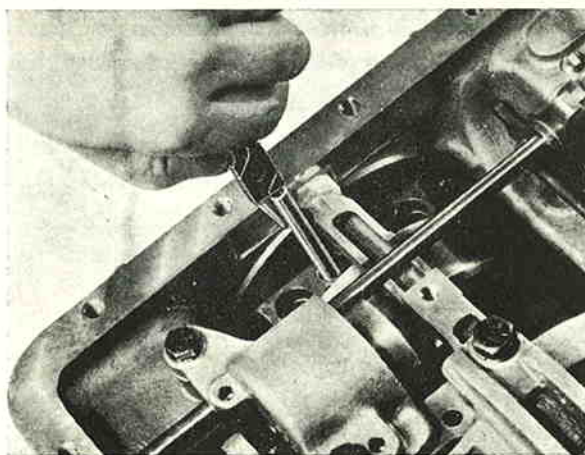

VOLVO
27961

Fig. 40. Removing converter inlet and outlet tubes using needle-nose pliers.

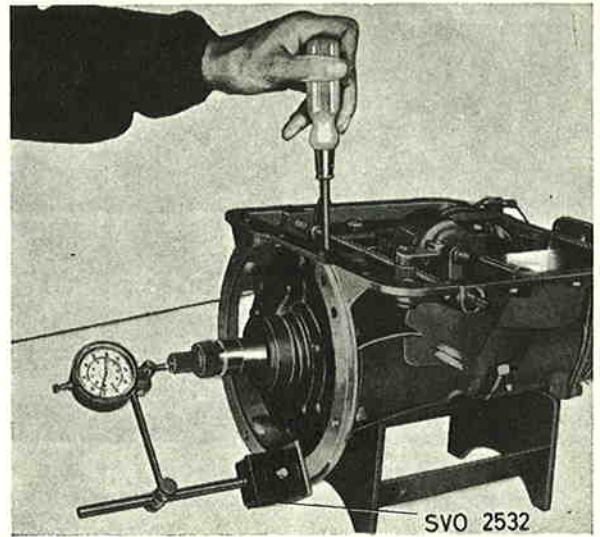

VOLVO
400 061

Fig. 41. Checking end float.

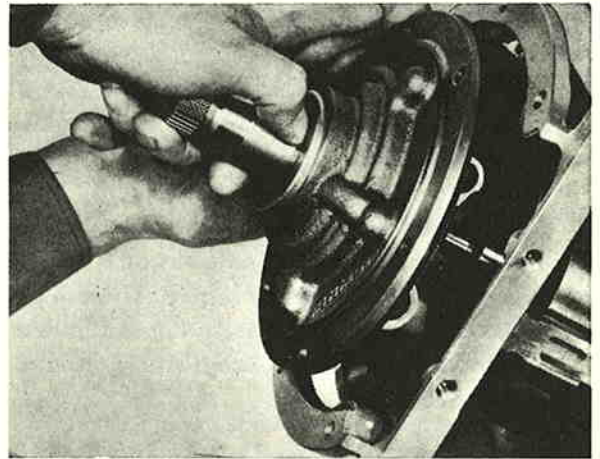

VOLVO
27665

Fig. 42. Removing front pump.

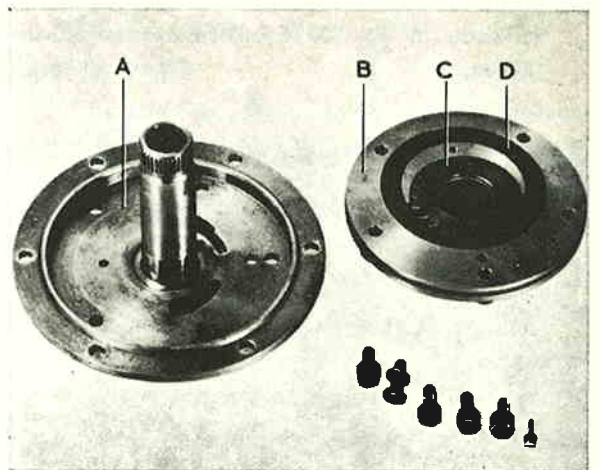

VOLVO
27669

Fig. 43. Converter support separated from front pump.

- A. Pump adaptor and converter support assembly
- B. Body and bush assembly
- C. Driving gear
- D. Driven gear

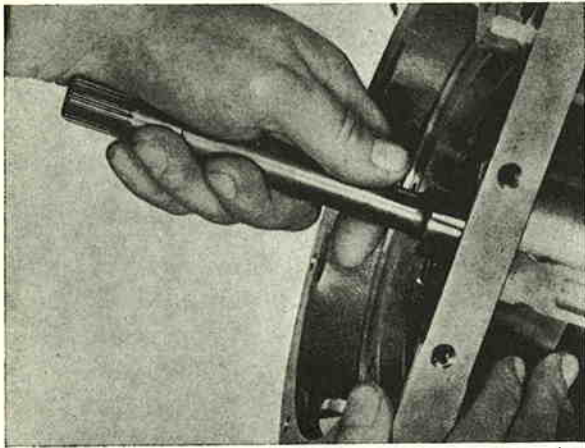

VOLVO
27970

Fig. 44. Withdrawing front clutch assembly.

Front and rear servos

16. Remove the two screws which retain the front servo to the body, withdraw the servo and the strut for the band.
17. Remove the snap ring in the servo with a small screwdriver. Take out the piston and separate the various parts. Drive out the slotted spring pin and lever pivot pin if necessary.
18. Unscrew the two screws which retain the rear servo and withdraw this and the strut.
19. Remove the snap ring with a small screwdriver. Take out the spring retainer, spring and piston. If necessary remove the slotted spring pin and lever pivot pin.

Front pump assembly

20. Remove the oil tubes in the housing. In case of difficulty pull them out with needle nose pliers as shown in Fig. 40. One of the tubes has an O-ring.

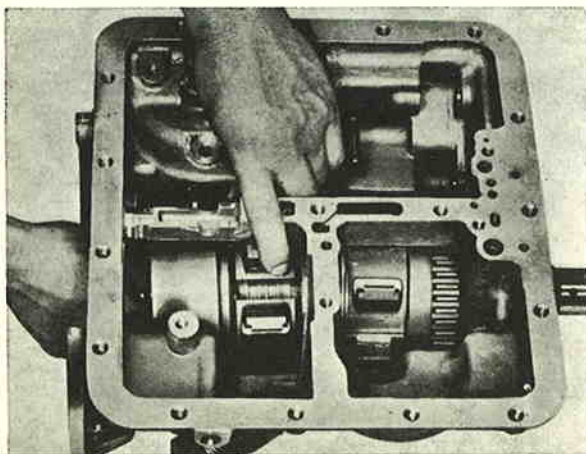

VOLVO
27668

Fig. 45. Withdrawing rear clutch and forward sun gear group.

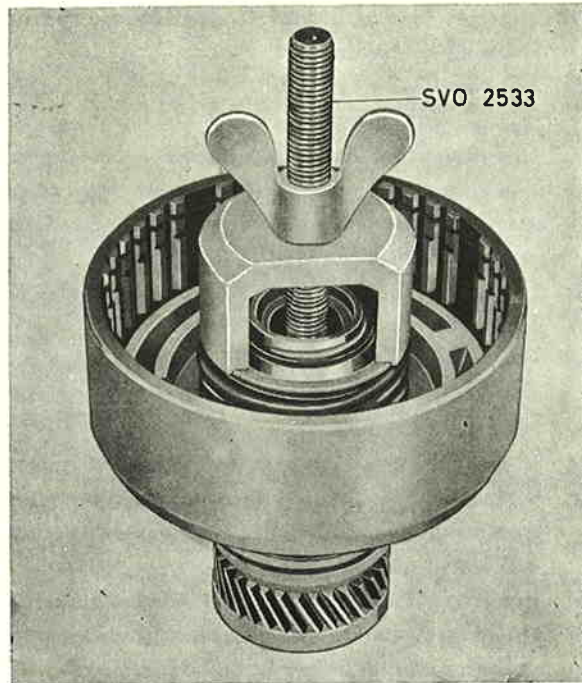

VOLVO
400 059

Fig. 46. Dismantling rear clutch.

21. Set up the dial indicator gauge as shown in Fig. 41 or with plate SVO 2532 and magnetic attachment. Place the point of the gauge against the shaft end, move the shafts and gears backwards and forwards and read off the end-float. This should be 0.010—0.030" (0.25—0.75 mm). Note the amount of play.
22. Unscrew the six bolts which retain the front pump to the body. Withdraw the pump and remove the gasket. Push the shaft inwards when withdrawing the pump, see Fig. 42.
23. Unscrew the five hexagon bolts and the slotted screw. Separate the pump body, gears and other parts, see Fig. 43.

Front clutch assembly

24. Withdraw the front clutch assembly and input shaft complete, see Fig. 44. Take care of the

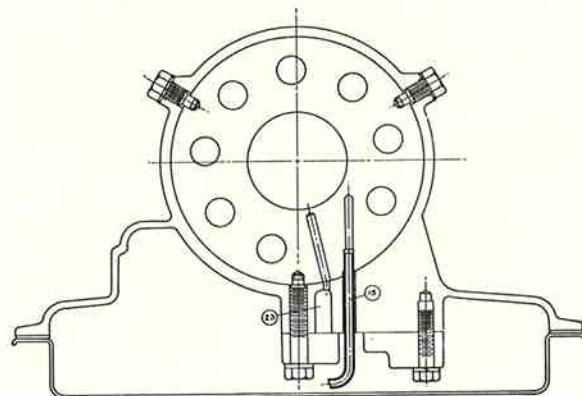

VOLVO
27959

Fig. 47. Centre support, retention and passages.

VOLVO
27963

Fig. 48. Withdrawing centre support and planet gears.

- thrust washers. Take out the front brake band.
25. Remove the snap ring with a screwdriver. Withdraw the input shaft. Take out the inner and outer plates and the clutch hub.
 26. Remove the snap ring, spring, and piston. If the piston is tight, lay the clutch body with the opening downwards on a bench and blow out the piston with compressed air.

Rear clutch assembly

27. Withdraw the rear clutch assembly together with the forward sun gear shaft, see Fig. 45.
28. Remove the two oil rings at the front of the shaft. Then withdraw the shaft. Take care of the two needle thrust bearings.
29. Remove the three oil rings from the clutch body hub.
30. Remove the snap ring and take out the pressure plate, inner and outer plates.
31. Place the special tool on the clutch as shown in Fig. 46. Tighten the wing nut until the snap ring

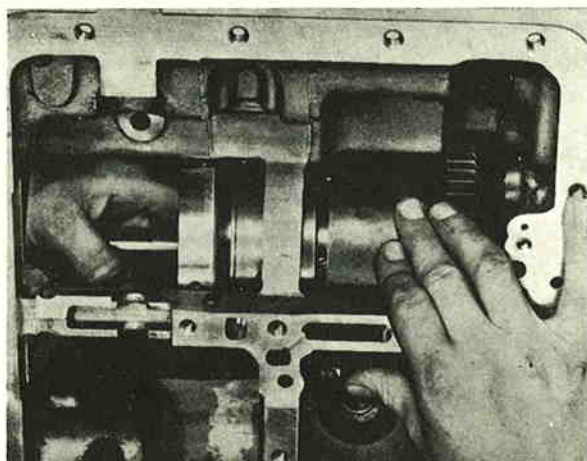
VOLVO
28017

Fig. 49. Withdrawing governor.

releases. Remove the snap ring and screw back the wing nut. Remove the special tool, then the retainer and spring. Withdraw the piston. If necessary blow out the piston with compressed air.

Centre support and planet gears

32. From the outside of the transmission case remove the two centre support screws, see Fig. 47. Withdraw the centre support and planet gears, see Fig. 48. Separate the centre support, one-way clutch and planet gears. Remove the snap ring and the outer race of the one-way clutch. Take out the rear brake band.

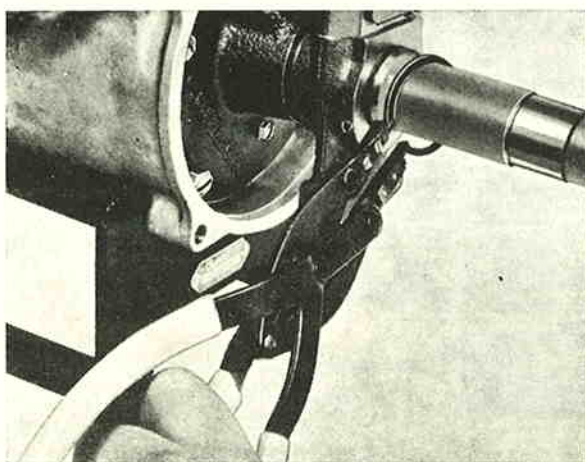
Governor

33. Remove the snap ring, see Fig. 49, and withdraw the governor. Take care of the detent ball.
34. Unscrew the two screws and take off the governor sleeve. Take off the spring retainer and separate the various parts. Unscrew the screws and withdraw the cover-plate.

Rear pump

35. Unscrew the five hexagon bolts and the slotted screw. Use a thin-walled or ground-diameter socket for the hexagon bolts. Withdraw the pump housing and driven gear. Mark the gear on the outside face so that it can be re-fitted correctly.
36. Remove the three oil sealing rings from the driven shaft. Mark the driving gear on the outside face and then withdraw it. Remove the drive key from the shaft and take out the pump plate.

Driven shaft

37. Withdraw the driven shaft. Note. Thrust washers (3 tubes) between output shaft and wall of transmission case. If necessary remove the snap ring and separate the ring gear from the driven shaft.

VOLVO
27992

Fig. 50. Pump adaptor, oil pan and extension housing gaskets.



VOLVO
27993

Fig. 51. Locating manual valve lever on detent ball spring.

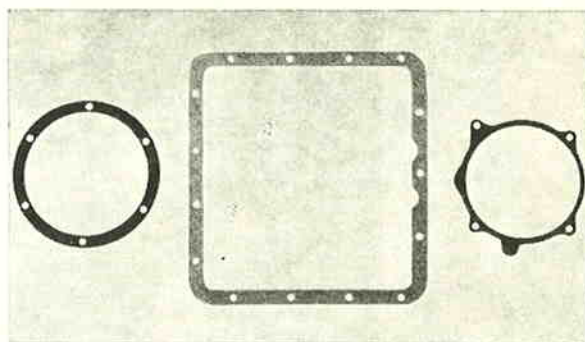
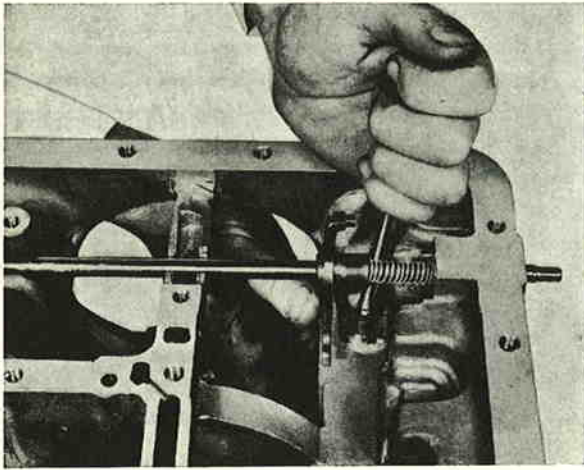
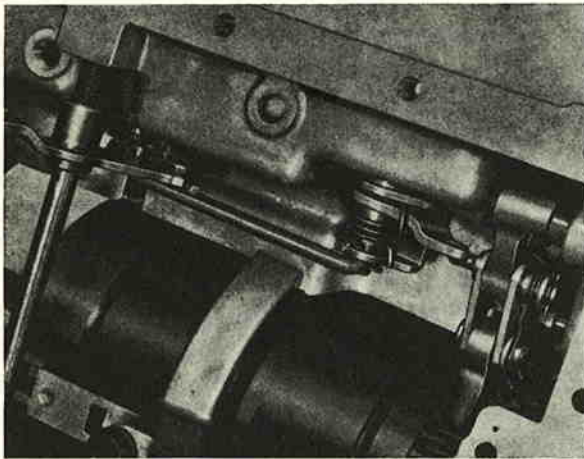

VOLVO
27972

Fig. 52. Parking pawl and linkage installed.

Shaft, parking pawl, and levers

38. Remove the locking clips with needle-nose pliers. Drive out the slotted spring pins in the manual valve lever shaft. Then drive inwards the slotted spring pin retaining the parking brake toggle pin. Separate the parts. The anchor pin for the parking pawl (the lower of the two pins as viewed with the gearbox inverted) can be withdrawn with a magnet or shaken out by up-ending the gearbox.
39. The throttle cable and other parts in the body are removed as necessary.

INSPECTING

After cleaning, all parts should be thoroughly checked for wear or other damage.

Check that the white metal bush for the driven shaft and the pins for the parking pawl linkage are firmly secured in the case. Note. White metal bush in rear wall of main case is not serviced separately.

Check the thrust washers and needle bearings for wear and any seizing. If the end-float is within the permissible limits, it can be taken for granted that the thrust washers are not worn. Check the gears for wear, seizing or tooth fractures. Also check that the pinions in the planet gear pinion carrier run easily on the needle bearings.

Check the brake bands and discs for wear, overheating or other damage.

ASSEMBLING

The utmost cleanliness must be observed when assembling the transmission.

Before assembling, all parts must be carefully washed in white spirit or paraffin (kerosene).

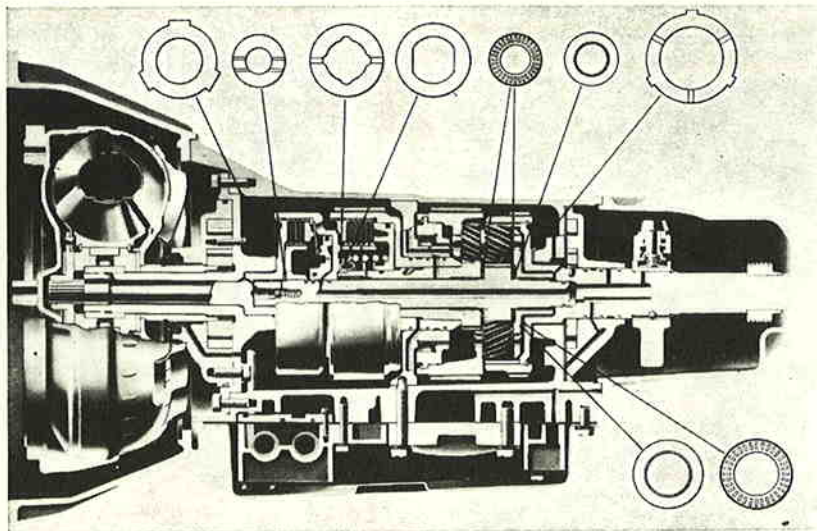

VOLVO
28010

Fig. 53. Location of thrust washers.

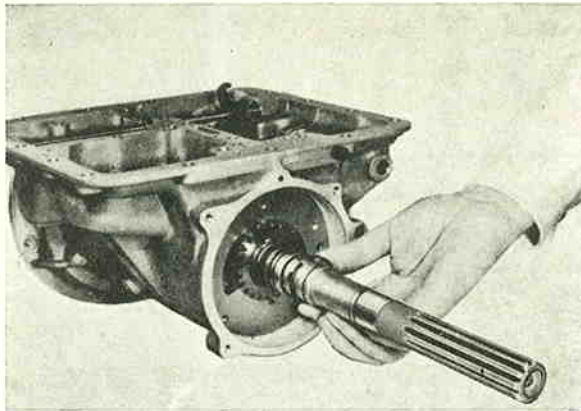

VOLVO
27994

Fig. 54. Installing driven shaft oil rings.

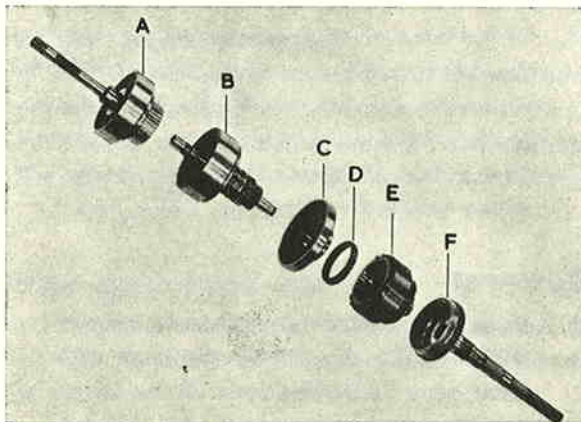

VOLVO
28019

Fig. 55. Gear train components.

- A. Input shaft and front clutch group
- B. Rear clutch and forward sun gear group
- C. Centre support
- D. One-way clutch
- E. Planet gears and rear drum assembly
- F. Driven shaft and ring gear assembly

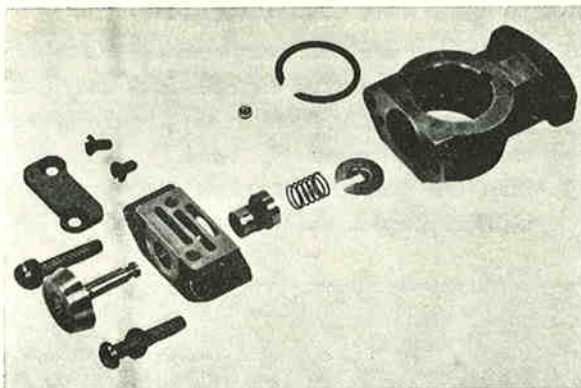

VOLVO
27664

Fig. 56. Governor assembly dismantled.

Use new gaskets when assembling, see Fig. 50. Lubricate the parts with an approved Type A Suffix A Automatic Transmission Fluid.

Tighten all bolts with a torque wrench in accordance with the torque chart in the "Specifications".

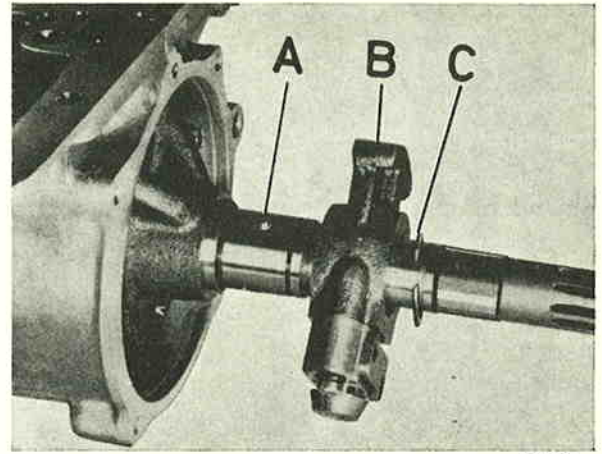

VOLVO
27995

Fig. 57. Governor and driven shaft.

- A. Drive ball
- B. Governor assembly
- C. Snap ring

Use sealing compound on the threads of the inhibitor switch and the pressure point plug. Note. Items not described in this section are assembled in the reverse order to dismantling.

Transmission case, shaft, parking pawl and levers

1. The transmission case is inverted on the bench cradle.
2. Assemble the shaft, parking pawl and levers in the reverse order to dismantling. Make sure that the springs for the levers are correctly fitted, see Fig. 52. Fitting the detent ball is facilitated by pressing down the ball using a short length of tubing as shown in Fig. 51.

Driven shaft

3. The thrust washer for the driven shaft, see Fig. 53, is stuck onto the transmission case with vaseline. The driven shaft complete with ring gear is then installed into the transmission case.

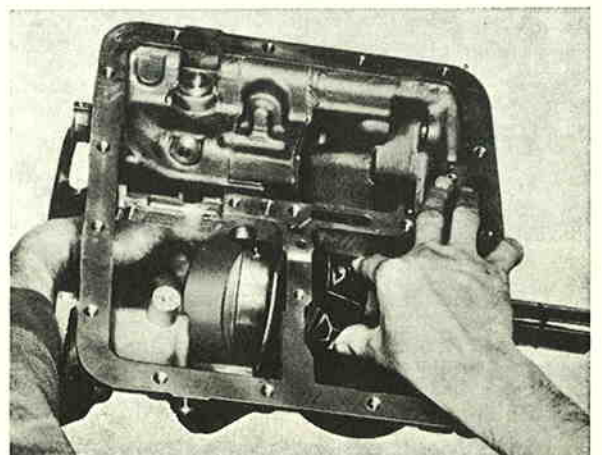

VOLVO
27663

Fig. 58. Installing rear brake band.

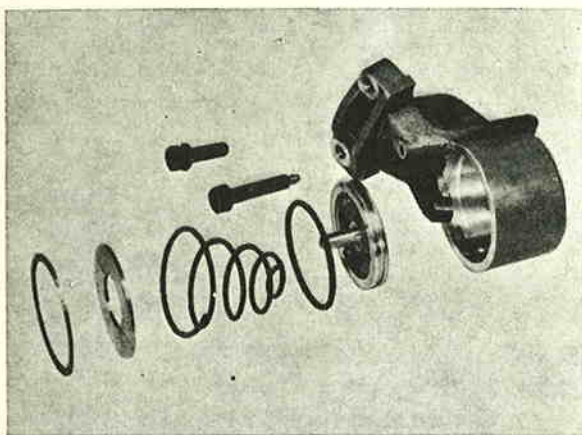

VOLVO
27661

Fig. 59. Rear servo assembly dismantled.

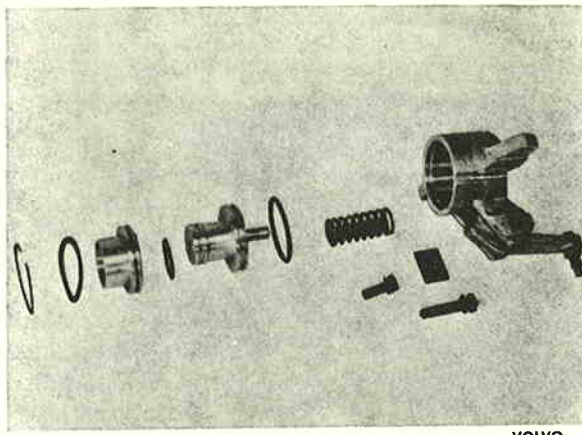

VOLVO
27660

Fig. 62. Front servo assembly dismantled.

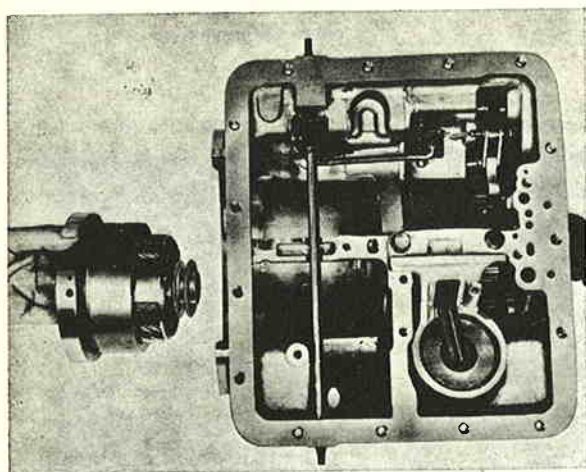

VOLVO
28020

Fig. 60. Installing centre support and planet gears with needle thrust bearing and plate washer.

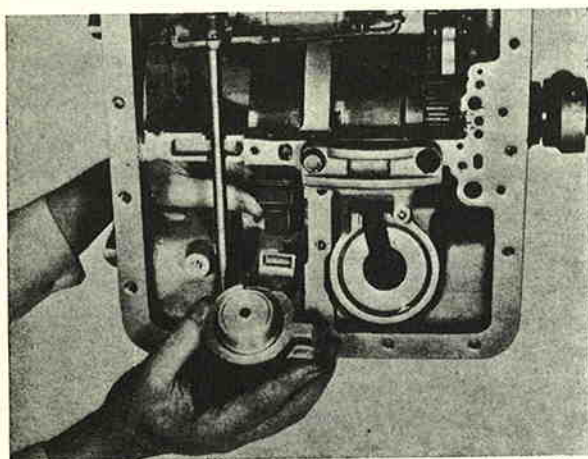

VOLVO
27984

Fig. 61. Installing front servo and strut.

Rear pump

4. Fit the pump plate, taking care that its two holes line up with those in the case. Then insert the pump drive key and fit the pump driving gear.

5. Fit the three oil sealing rings on the shaft, see Fig. 54. Exercise care when doing this as the oil sealing rings are very fragile. Stand the box on its front end and support under the shaft. Centre the oil rings. The pump body with driven gear is then fitted.

Governor

6. Place the governor drive ball in the shaft as shown in Fig. 57. Fit the governor with the cover-plate facing the rear. Fit the snap ring.

Rear brake band and servo

7. Place the rear brake band in position in the case, see Fig. 58. Then fit the rear servo assembly. Tighten only the rear (short) servo screw since the long one also locates the centre support.

Planet gear and centre support

8. Assemble the planet gear, one-way clutch and centre support, see Fig. 60. Stick the thrust plate and needle thrust bearing to the planet gear cover with vaseline.
9. Turn the fluid passage holes in the centre support upwards and fit the assembled unit into

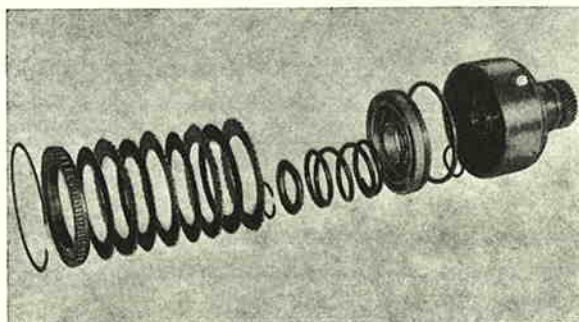

VOLVO
28021

Fig. 63. Rear clutch dismantled.

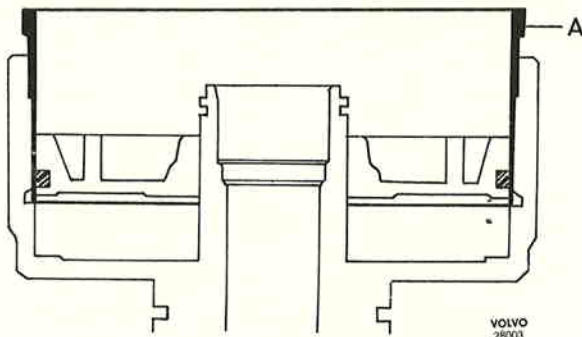

Fig. 64. Installing piston for rear clutch.

A. Fitting ring SVO 2534

the transmission case. (Note that the holes point downwards when the transmission is turned the right way up, see Fig. 47).

10. Fit the two centre support screws from outside. Remember that the lock washers also serve as sealing washers so that the flat surface should face inwards. Then tighten the servo screw locating the support.

Front brake band and servo

11. Place the front brake band in position, see Fig. 61. Stick the strut to the servo lever with vaseline. Fit the servo. The shorter bolt is fitted at the front. Make sure that the servo strut is correctly engaged with the slot in the brake band.

Rear clutch

12. Fit the sealing rings for the piston. Use a fitting ring and fit the piston in the clutch case, see Fig. 64.

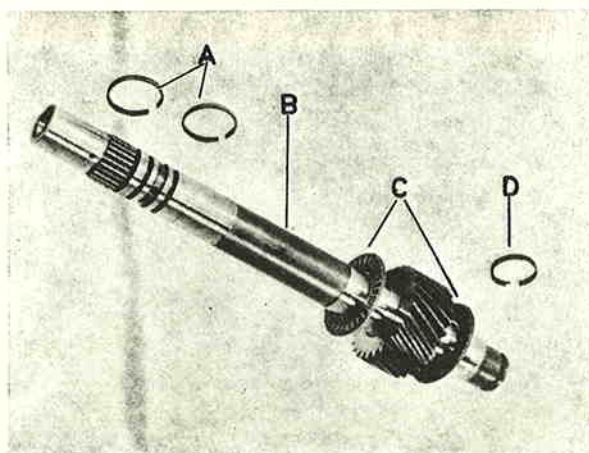

Fig. 65. Forward sun gear components.

- A. Oil sealing rings, front clutch
- B. Forward sun gear assembly
- C. Needle thrust washers
- D. Oil sealing ring, governor feed

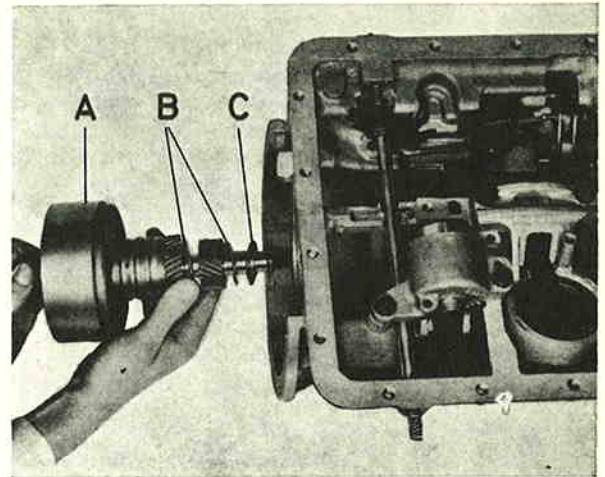

Fig. 66. Installing rear clutch and forward sun gear group.

- A. Rear clutch
- B. Needle thrust bearings
- C. Thrust washer plate

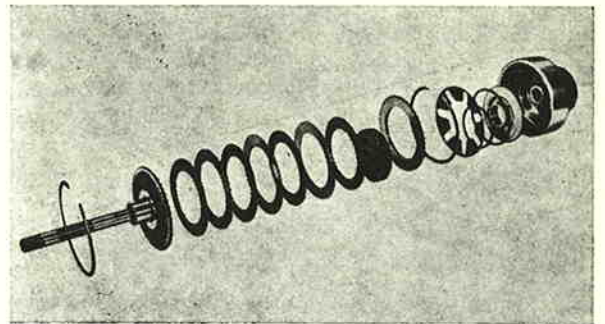

Fig. 67. Front clutch dismantled.

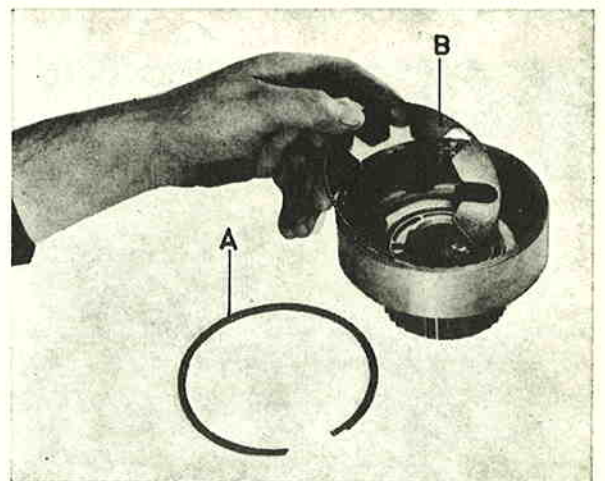
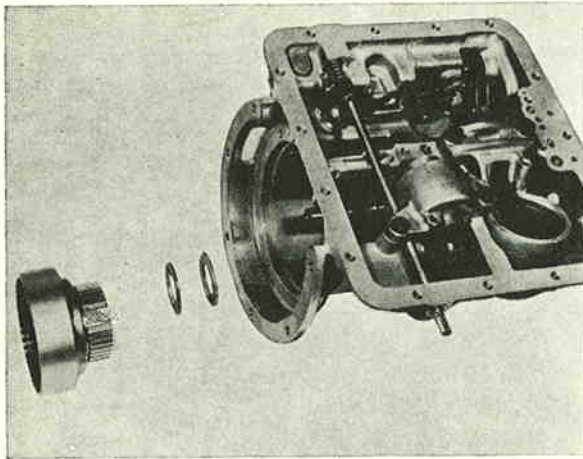

Fig. 68. Front clutch details.

- A. Snap ring
- B. Front clutch spring



VOLVO
27997

Fig. 69. Installation sequence, front clutch cylinder thrust and backing washers.

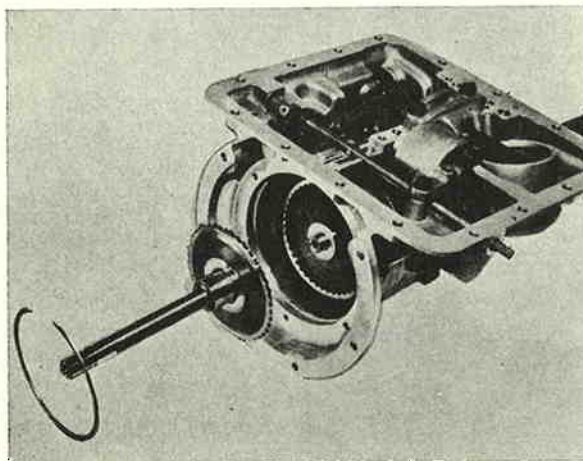

VOLVO
27998

Fig. 70. Installation sequence, front clutch snap ring, input shaft and thrust washer.

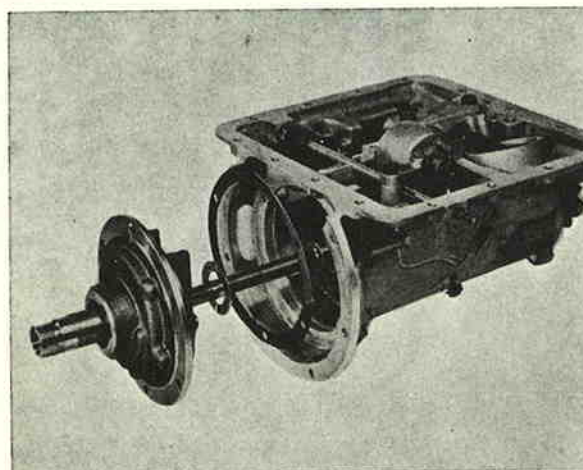

VOLVO
27999

Fig. 71. Installation sequence, front pump assembly, thrust washer and gasket.

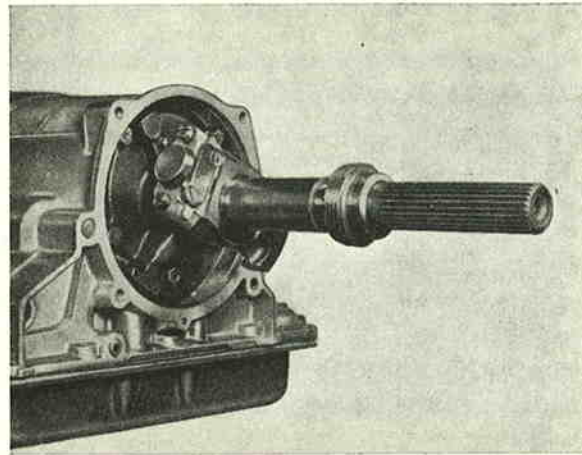

VOLVO
28022

Fig. 72. Installing speedometer gear.

13. Fit the spring, spring seat and snap ring using special tool SVO 2533, which is used when dismantling, see Fig. 46.
14. Install the clutch plates. Note that the outer plates are coned and that all the plates should be fitted with the cone facing the same direction. Begin with an outer plate and then fit inner and outer plates alternately. Fit the pressure plate and snap ring.
15. Place the front needle thrust bearing on the rear sun gear shaft. Fit the shaft in the rear clutch assembly. Install the oil sealing rings, see Fig. 65.
16. Install the rear needle thrust bearing and fit the clutch in the gearbox as shown in Fig. 66.

Front clutch

17. Fit the sealing ring on the piston and a new O-ring in the drum. Insert the piston into the drum. Fit the front clutch spring with the dishing facing to the rear, see Fig. 68. Place in the snap ring.

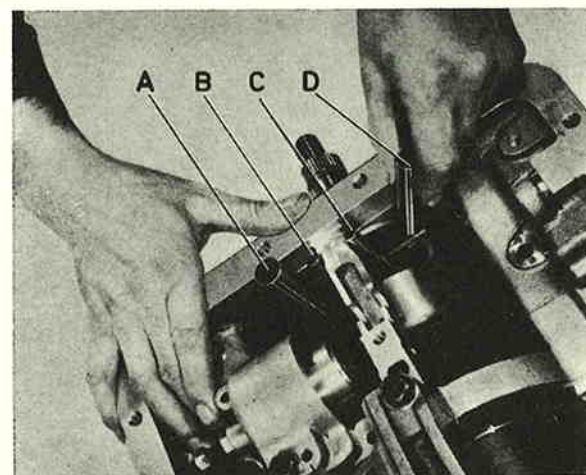

VOLVO
27975

Fig. 73. Location of oil tubes, front of gearbox.

- | | |
|---------------------|----------------------|
| A. Front pump inlet | C. Converter inlet |
| B. Converter outlet | D. Front pump outlet |

18. Install the clutch assembly with its two different thrust washers in the gearbox, see Fig. 69. Be careful not to damage the oil sealing rings. For identifying the thrust washers, see Fig. 53.
19. Fit the pressure plate, inner and outer plates, and hub. Fit the thrust washer for the clutch hub and input shaft into the front clutch, see Fig. 70. Fit the snap ring.

The front and rear clutches can also be installed in the gearbox as an assembly. In this case they are first assembled individually. The rear clutch is then stood straight up, the thrust washer for the clutch hub centred, both the rear thrust washers placed on, and after this the rear clutch and sun gear are assembled with the front clutch.

Front pump

20. Fit the O-ring on the pump body then assemble the pump in the reverse order to dismantling.
21. Stick on the thrust washer with vaseline and then fit the pump with a new gasket on the transmission case, see Fig. 71. Re-check the endfloat in accordance with point 21, page 22.

Extension housing

22. Place the speedometer gear correctly on the driven shaft as shown in Fig. 72. Fit the extension housing with a new gasket and fit the drive flange with washer and "Wedglok" screw.

Valve bodies assembly

23. When assembling, all the component parts which have been dismantled should be scrupulously cleaned and lubricated with approved

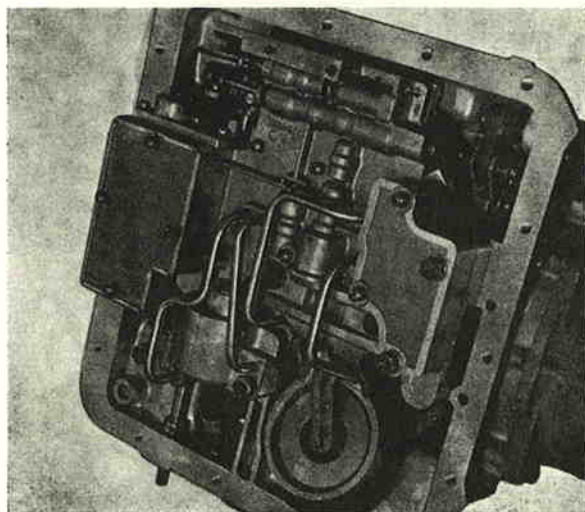

Fig. 74. Retention of front and rear pump strainers.

Automatic Transmission Fluid prior to reassembly in the reverse order to dismantling. Line up the component parts of the valve bodies assembly by using two of the retaining bolts. Check the free movement of all valves in their bores. Check that the strainers are flat so that they make a complete seal when screwed down. Tighten the screws to the specified torque.

24. Fit the oil tubes for the pump and converter on the front pump, see Fig. 73. Do not forget the O-ring for the pump inlet tube.
25. Fit the valve bodies assembly onto the gearbox. Connect the throttle cable and fit the four oil tubes as shown in Fig. 74.

Miscellaneous

26. Adjust the brake bands, see "Adjusting the front brake band" and "Adjusting the rear brake band" on page 17. Adjust the starter inhibitor switch, see "Adjusting the starter inhibitor switch" on page 17.
27. Fit the oil pan with a new gasket.
28. On cars which have six control positions, the stop bracket is fitted as shown in Fig. 75. Adjustment is carried out as follows:
 - A. Turn the lever **clockwise** as far as it will go ("P" position) and then four "catches" **anti-clockwise**.
 - B. Push the stop bracket forwards so that it comes 3—4 mm ($\frac{1}{8}$ — $\frac{5}{32}$ "") from the lever, see "A" in the figure. Tighten the bracket in this position.

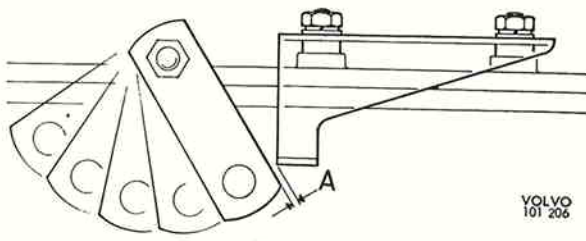

Fig. 75.

FITTING

The converter, converter housing and gearbox are fitted in the reverse order to removing. In order to ensure correct engagement of the front oil pump drive, it is recommended to rotate the converter so that the drive fingers on the hub will be in the 9 o'clock and 3 o'clock positions. The slots of the front oil pump driving gear are rotated to a similar position with the aid of a screwdriver or similar tool. Connect the leads for the starter inhibitor switch and reversing light correctly, see Fig. 76.

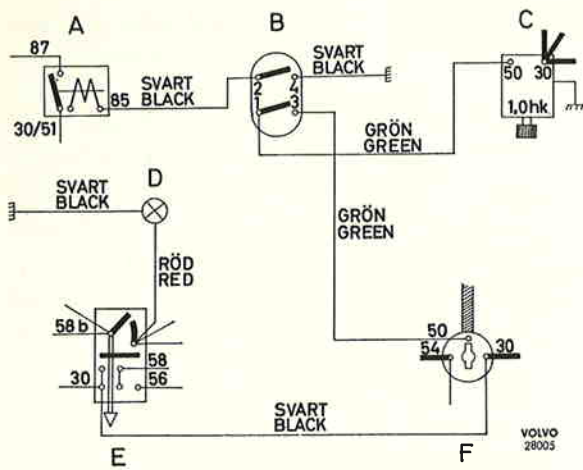

Fig. 76. Wiring diagram.

- A. Reversing light relay
- B. Switch on gearbox for starter inhibitor and reversing light
- C. Starter motor
- D. Quadrant illumination for selector control
- E. Lighting switch
- F. Ignition switch

2. Slacken and pull off the steering wheel, see Part 6. Remove the screws for the indicator quadrant and lift this up. Disconnect the indicator quadrant lighting leads. Release and remove the left and right casing halves over the direction indicator switch and selector control.
3. Remove the direction indicator switch. Then release the jacket tube and withdraw it together with the selector control.
4. Disconnect and remove the link between the operating rod and indicator assembly. Remove the snap rings and separate the operating rod, hand lever, jacket tube and other parts.
5. Release the indicator assembly and withdraw it from the steering column. Remove the snap ring and separate the various parts.

Inspecting

All the parts should be inspected, particularly as regards wear. Worn bushings, linkages, etc., must be replaced.

Assembling and fitting

The selector controls are fitted in the reverse order to removing. Lubricate the links and bearings of the control parts with Mobilgrease No. 2 or corresponding. Adjust the selector controls in accordance with the instructions under "Adjusting the selector controls", page 15.

SELECTOR CONTROLS

Removing and dismantling

1. Disconnect the connecting linkage from the control lever on the gearbox and the operating lever. Release and remove the control lever.

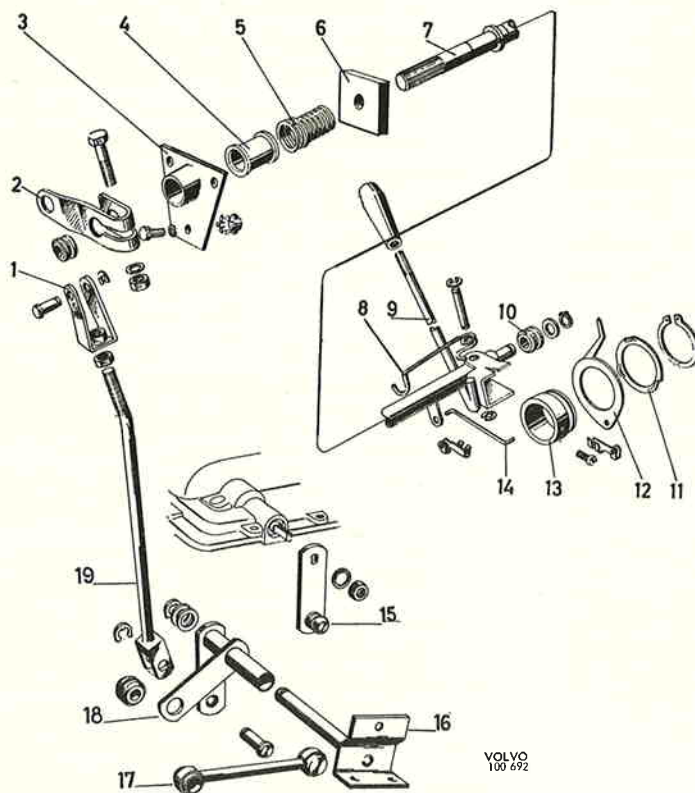

Fig. 77. Selector controls, late prod.

- 1. Yoke
- 2. Arm
- 3. Bearing plate
- 4. Bushing
- 5. Spring
- 6. Seal
- 7. Operating rod
- 8. Spring
- 9. Selector lever
- 10. Bushing
- 11. Spring
- 12. Pointer
- 13. Mounting for pointer
- 14. Link
- 15. Lever attachment
- 16. Lever bracket
- 17. Link rod
- 18. Lever arm
- 19. Control rod

FAULT TRACING

ROAD-TESTING

(Used together with the fault-tracing scheme).

It is important to gain as much information as possible on the precise nature of any fault. If possible, go out in the car with the customer and get him to demonstrate the fault. In all cases, the following road-test procedure should be carried out completely as there may be more than one fault.

Test No.

1. Check that the starter only operates with the selector in "P" and "N" and that the reversing light operates only in "R".
2. Apply the brakes and, with the engine running at normal idling speed, select "N—D", "N—L" and "N—R". Transmission engagement should be felt in each position selected.
3. Check the converter stall speed with the transmission in "L" and "R". Check for slip or clutch squawk.

Note. Do not stall for longer than 10 seconds or the transmission will overheat.

4. With the transmission at normal running temperature, select "D". Release the brakes and accelerate with minimum throttle opening. Check for 1—2 and 2—3 shifts. Note. At minimum throttle openings, the shifts may be difficult to detect. Confirmation that the transmission is in 3rd gear may be obtained by selecting "L", when a 3—2 downshift should be felt.
5. At just over 30 m.p.h. (50 km.p.h.), select "N", switch off the ignition and let the car coast. At 30 m.p.h. (50 km.p.h.) switch on the ignition and select "D". The engine should then start through the rear wheels, indicating that the rear oil pump of the transmission is operating.
- 6a. Stop and restart using full throttle acceleration. Check for 1—2 and 2—3 shifts according to the shift speed table in the specifications.
- b. At 25 m.p.h. (40 km.p.h.) in 3rd gear, depress the accelerator to full throttle position. The car should accelerate in 3rd gear and should not downshift to 2nd.
- c. At 30 m.p.h. (50 km.p.h.) in 3rd gear, depress the accelerator to the kick-down position. The transmission should downshift to 2nd gear.

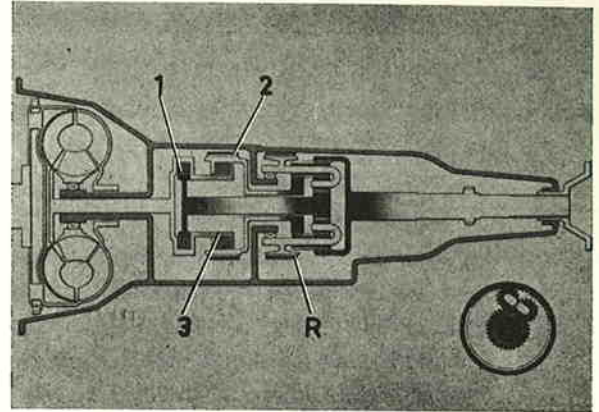

Fig. 78. Principle diagram for fault tracing.

1. Front clutch gives 1st gear
2. Front brake band gives 2nd gear
3. Rear clutch gives 3rd gear
- R. Rear brake band gives reverse and engine braking in "L"

- d. At 15 m.p.h. (25 km.p.h.) in 3rd gear, depress the accelerator to the kick-down position. The transmission should downshift to 1st gear.
- 7a. Stop and restart using forced throttle acceleration. Check for 1—2 and 2—3 shifts according to the shift speed table in the specifications.
- b. At 40 m.p.h. (65 km.p.h.) in 3rd gear, release the accelerator and select "L". Check for 3—2 downshift and engine braking. Check for roll-out 2—1 downshift at about 3 m.p.h. (5 km.p.h.) and engine braking.
8. Stop, and with "L" still engaged, release brakes and, using full throttle, accelerate to 20 m.p.h. (30 km.p.h.). Check for no slip or clutch squawk and no upshifts.
9. Stop and select "R". Release brakes and reverse using full throttle if possible. Check for no slip or clutch squawk.
10. Stop on the brakes facing downhill on a gradient and select "P". Release the brakes and check that the parking pawl will hold the car. Re-apply the brakes before disengaging the parking pawl. Repeat with the car facing uphill. Check that the selector is trapped by the gate in "P".

FAULT-TRACING SCHEME

(To be used in conjunction with the road-test procedure).

TEST	FAULT	ACTION	
1.	Starter will not operate in "P" or "N"	19	
	Starter operates in all selector positions	20	
2.	Excessive bump on engagement of "D", "L" or "R"	4, 3	
3.	If stall speed higher than specified:		
	a. with slip and squawk in "L"	1, 2, 3, 13, 11	
	b. with slip and squawk in "R"	1, 2, 3, 13, 12	
	If stall speed lower than specified, check engine performance		
4.	If stall speed more than 600 r.p.m. lower than specified	21	
	No drive in "D" (if normal in "L", omit 11 and 13; if no drive in "D", "L" or "R", add 17)	1, 2, 3, 13, 11, 16	
	Delayed or no 1—2 shift	3, 14, 13, 5, 6	
	Slip on 1—2 shift	2, 3, 5, 6, 7, 13	
	Delayed or no 2—3 shift. (If normal in "R", omit 12).	3, 14, 13, 5, 6, 12	
	Slip or engine run-up on 2—3 shift	2, 3, 5, 13, 12	
	Bumpy gear shifts	3	
	Drag in "D 2" and "D 3"	8	
	Drag on 2—3 shift.	5, 6	
	5.	Engine will not start through rear wheels	22
	6 a.	Slip and squawk or judder on full throttle take-off in "D"	
		Loss of performance and overheating in "D 3" (seized stator).	1, 2, 3, 13, 11
Continue as for test 4 above		21	
b.	Transmission downshifts too easily	3	
	c, d. Transmission will not downshift	3, 13, 14	
7 a.	As test 6a above		
b.	No 3—2 downshift or engine braking	1, 5, 6, 7, 12	
	No 2—1 downshift or engine braking	8, 9, 10	
8.	Slip and squawk or judder on take-off in "L"	1, 2, 3, 13, 11	
	Transmission upshifts	1	
9.	Slip and squawk or judder on take-off in "R"	1, 2, 3, 13, 12	
	Slip but no judder on take-off in "R" (if engine braking available in "L 1", omit 8, 9, 10)	1, 2, 3, 8, 9, 10	
	Drag in "R"	5	
	No drive in "R" (if engine braking available in "L 1", omit 8, 9, 10)	1, 2, 3, 8, 13, 9, 10, 12	
10.	No park	1, 15	
Mis- cell- aneous	Screech or whine, increasing with engine speed	17	
	Grinding or grating noise from gearbox	18	
	Knocking noise from torque converter area	23	
	At high speeds in "D 3", transmission downshifts to "D 2" and immediately back to "D 3"	12	

Action

1. Check manual linkage adjustment.
2. Check fluid level.
3. Check adjustment of downshift valve cable using line pressure gauge and tachometer.
4. Reduce engine idling speed.
5. Check front band adjustment.
6. Check front servo seals and fit of tubes.
7. Check front band for wear.
8. Check rear band adjustment.
9. Check rear servo seal and fit of tubes.
10. Check rear band for wear.
11. Examine front clutch and seals, also front sun gear shaft sealing rings. Verify that cup plug in driven shaft is not leaking or dislodged.
12. Examine rear clutch, check valve, and seals. Check fit of tubes.
13. Strip valve bodies and clean.
14. Strip governor valve and clean.
15. Examine parking pawl, gear and internal linkage.
16. Examine one-way clutch.
17. Strip and examine front pump and drive fingers.
18. Strip and examine gear train.
19. Adjust starter inhibitor switch inwards.
20. Adjust starter inhibitor switch outwards.
21. Replace torque converter.
22. Check rear pump drive pin.
23. Examine torque converter drive plate for cracks or fracture.

FAULT-TRACING ON THE CONVERTER

The converter housing is welded together and can therefore not be repaired but must be replaced in the event of defects. There is no drain plug since fluid changes do not occur and fluid filling is done through the transmission.

The stall speed means the speed obtained at full throttle on the engine with the lock-up engaged but with the car stationary. Check that the transmission has the correct running temperature and that the fluid level is correct before the stall speed test. The test must not take place longer than ten seconds, otherwise the transmission will overheat.

Fault-tracing on the converter is carried out as follows:

1. If the general performance of the vehicle is below standard, check the converter stall speed with an accurate tachometer by applying maximum pressure on the footbrake pedal, selecting "Lock-up" and fully depressing the accelerator. If the stall speed is up to 300 r.p.m. below that specified, the engine is not developing its full power.
2. Inability to start on steep gradients combined with poor acceleration from rest indicates that the converter stator one-way clutch is slipping or that the stator support is fractured. This condition permits the stator to rotate in an opposite direction to the turbine and torque multiplication cannot occur. Check the stall speed and, if it is more than 600 r.p.m. below that specified, the converter assembly must be replaced.
3. Below standard acceleration in 3rd gear above 30 m.p.h. (50 km.p.h.) combined with a substantially reduced maximum speed, indicates that the stator one-way clutch has locked in the engaged condition. The stator will then not rotate with the turbine and impeller, therefore the fluid flywheel phase of the converter performance cannot occur. This condition will also be indicated by excessive overheating of the transmission, although the stall speed will remain as specified. In this case the converter assembly must be replaced.
4. Stall speed which is higher than that specified, indicates that the converter is not receiving its required fluid supply or that slip is occurring in the clutches of the automatic gearbox.

TOOLS

The following special tools are required for repairing the transmission:

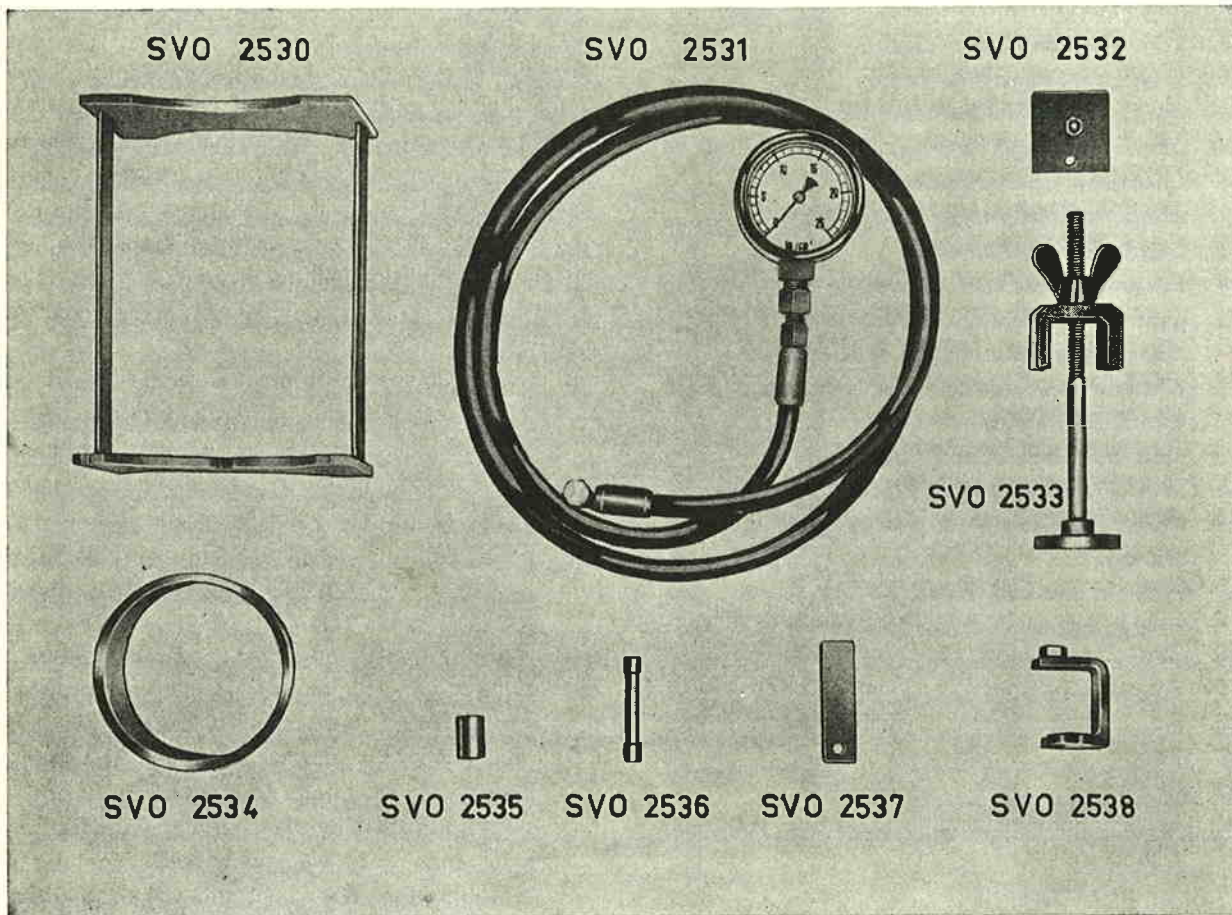

YQLV9
100 107

- SVO 2530 Fixture for dismantling and assembling the transmission.
- SVO 2531 Manometer complete with hose and connection for checking the oil pressure.
- SVO 2532 Attaching plate for magnetic holder when measuring end- float of input shaft.
- SVO 2533 Press tool for compressing clutch when removing and fitting the snap ring.

- SVO 2534 Fitting ring for piston in rear clutch.
- SVO 2535 5/16" square socket for adjusting rear brake band.
- SVO 2536 1/4" square socket for adjusting front brake band.
- SVO 2537 Spacer for adjusting front brake band.
- SVO 2538 Spanner for locknut on contact for starter inhibitor and reversing light.

SPECIFICATIONS

Make and type	Borg-Warner, type 35
Type designation	AS 1 — 35 EN
Colour of type plate	Light buff
Reduction ratios:	
1st gear	2.39: 1
2nd gear	1.45: 1
3rd gear	1: 1
Reverse	2.09: 1
	} × Converter ratios
Number of teeth, front sun gear	32
rear sun gear	28
planet gear, short	16
planet gear, long	17
ring gear	67
Size of converter	9 1/2" (24 cm)
Torque ratio in converter	2: 1—1: 1
Normal stall speed, B 18 A engine	2100 r.p.m.
B 18 D engine	2250 r.p.m.
Weights:	
Gearbox	lb. kg
Converter case	82 37.2
Converter	8.2 3.7
Total, without fluid	24 10.9
Weight of fluid	114.2 51.8
Total, with fluid	13.25 6.0
Total, with fluid	127.45 57.8
Fluid, type	Type A Suffix A Automatic Transmission Fluid
Fluid capacity	11 pints (6.2 litres)
Normal operating temperature of fluid	approx. 212—240° F
Bulb for selector control lighting	(100—115° C)
	12 V
	2 W
	Ba 7s Socket

Approximate shift speeds

	1—2 shift		2—3 shift		3—2 shift		3—1 shift	
	km.p.h.	m.p.h.	km.p.h.	m.p.h.	km.p.h.	m.p.h.	km.p.h.	m.p.h.
Full throttle	43	27	72	45	22	14	—	—
Kick-down	60	37	102	63	90	56	48	30

SPRINGS FOR CONTROL SYSTEM

SPRING	Approximate length		Effective number of turns	Wire diameter	
1—2 shift valve	1.094"	27.8 mm	13.5	0.024"	0.61 mm
Converter exhausting valve	0.70"	17.8 mm	12	0.018"	0.46 mm
Rear pump check valve	0.617"	15.7 mm	3	0.019"	0.49 mm
*Rear pump check valve	0.617"	15.7 mm	5	0.024"	0.61 mm
Primary regulator valve	2.850"	72.4 mm	14 1/4	0.054"	1.37 mm
*Primary regulator valve	2.850"	72.4 mm	15	0.056"	1.42 mm
Servo orifice control valve	1.086"	27.6 mm	24	0.025"	0.64 mm
*Servo orifice control valve	1.213"	30.8 mm	25	0.024"	0.61 mm
Modulator valve	1.069"	27.2 mm	19	0.028"	0.71 mm
*Modulator valve	1.069"	27.2 mm	19	0.028"	0.71 mm
Secondary regulator valve	2.593"	65.9 mm	16 1/2	0.056"	1.42 mm
2—3 shift valve (inner spring)	1.59"	40.4 mm	19 1/2	0.036"	0.91 mm

Throttle valve (inner spring)	0.807"	20.5 mm	28	0.018"	0.46 mm
*Throttle valve (inner spring)	0.898"	22.8 mm	28	0.018"	0.46 mm
Throttle valve (outer spring) 1.174—1.185"	29.8—30.1 mm	19 1/2	0.032"	0.81 mm	
*Throttle valve (outer spring) 1.174—1.185"	29.8—30.1 mm	18	0.032"	0.81 mm	

*Alternative springs.

TIGHTENING TORQUES

APPLICATION	Lb.in.	Lb.ft.	Kgm
Torque converter — drive plate	300—600	25—30	3.5—4.1
Transmission case — converter housing	100—120	8—10	1.1—1.4
Extension housing — transmission case	100—120	8—10	1.1—1.4
Oil pan — transmission case	100—120	8—10	1.1—1.4
Front servo — transmission case	100—120	8—10	1.1—1.4
Rear servo — transmission case	120—154	10—13	1.4—1.8
Pump adaptor — front pump body	210—265	17—22	2.4—3.0
Slotted screws	25—35	2—3	0.3—0.4
Pump adaptor — transmission case	100—225	8—18.5	1.1—2.6
Rear pump — transmission case	55—66	4—5	0.6—0.7
Slotted screws	20—30	1.7—2.5	0.25—0.35
Centre support — transmission case	120—154	10—13	1.4—1.8
Outer lever — manual valve shaft	120—180	10—15	1.4—2.1
Pressure point	50—60	4—5	0.6—0.7
Oil pan drain plug	120—168	10—14	1.4—1.9
Oil tube collector — lower body	20—30	1.7—2.5	0.25—0.35
Governor line plate — lower body	20—30	1.7—2.5	0.25—0.35
Lower body end plate — lower body	20—30	1.7—2.5	0.25—0.35
Upper body end plate front or rear — upper body ..	20—30	1.7—2.5	0.25—0.35
Upper body — lower body	20—30	1.7—2.5	0.25—0.35
Valve bodies assembly — transmission case	50—60	4—5	0.6—0.7
Front pump strainer — lower body	20—30	1.7—2.5	0.25—0.35
Downshift valve cam bracket — valve body	20—30	1.7—2.5	0.25—0.35

Governor

Inspection cover — extension housing		Tighten fully with large screwdriver	
Cover plate — governor body	20—30	1.7—2.5	0.25—0.35

Brake band adjustment

Adjusting screw nut — front servo lever	180—240	15—20	2.1—2.8
Adjusting screw locking nut, rear servo — case	300—360	25—30	3.5—4.1

Special threaded parts

Starter inhibitor switch locknut	48—72	4—6	0.6—0.8
Downshift valve cable adaptor — transmission case ..	96—108	8—9	1.1—1.2
Filler tube connector adaptor — transmission case	240—360	20—30	2.8—4.1
Filler tube — connector sleeve nut	200—220	17—18	2.4—2.5
Stone guards — converter	17—19	1.4—1.6	0.19—0.22
Coupling flange — driven shaft	240—300	20—25	2.8—3.5

